

Installation Instructions

275332 275333 275334 48mm Dual Flush Button Assembly

1.

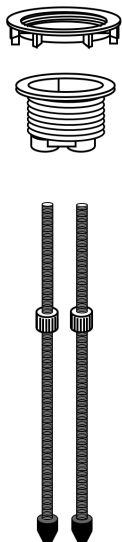

2.

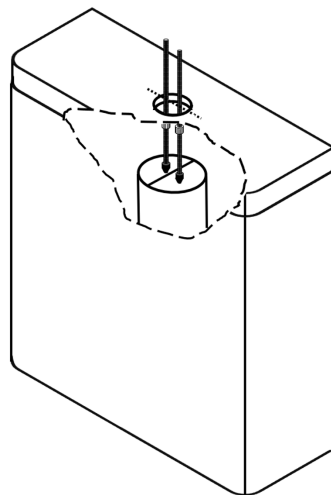

3.

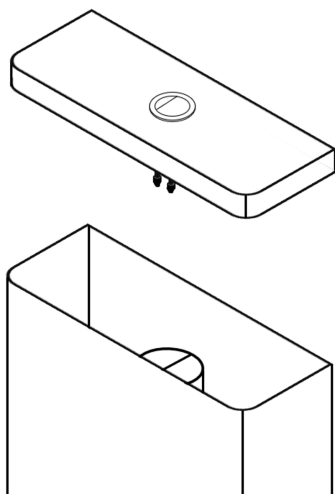

4.

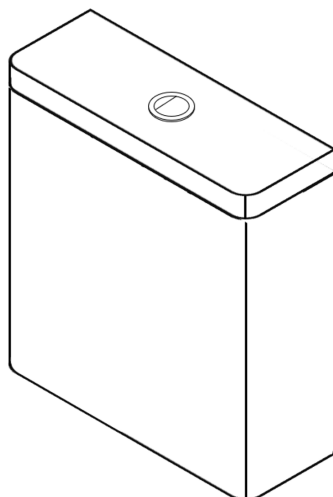

Installation

1. Loosen the locking nut from each flush rod. Unscrew and remove the flush rods and the outer locking nut from the button housing.
2. Insert the flush rods into cistern lid hole, until they touch the outlet valve. Mark the flush rods where they protrude from the cistern. Cut the rods 15mm below this mark.
3. Fit the flush button to the cistern lid, ensuring the full flush (larger button) is on the right. Tighten the outer locking nut to secure the flush button to the cistern lid. Re-fit the flush rods back and securely tighten their locking nuts.
4. Test the operation of the flush button and confirm the toilet flushes effectively.

Troubleshooting

1. When depressing the flush button, there should be 1-2mm movement before the toilet starts to flush. It is not necessary to hold the button down while it flushes. If the button travels too far before the flush starts, or if the toilet will not flush completely, unscrew the flush rods to increase their length and re-tighten the locking nuts.
2. The toilet should not start to trickle or run when the cistern lid and button are fitted onto the cistern. If this occurs, remove the flush rods, re-measure and reinstall per the installation steps above as they are likely too long.
3. The flush rods should not be difficult to operate and the buttons should not feel stiff or get stuck. If this occurs, position the flush rod spacer so that it is in the middle of the flush rod length and re-test and ensure the flush rods are aligned with the outlet valve strike plates.