

Venice

VE110503CG

Classic Gold Uplift Tower Basin Mixer

All dimensions in mm

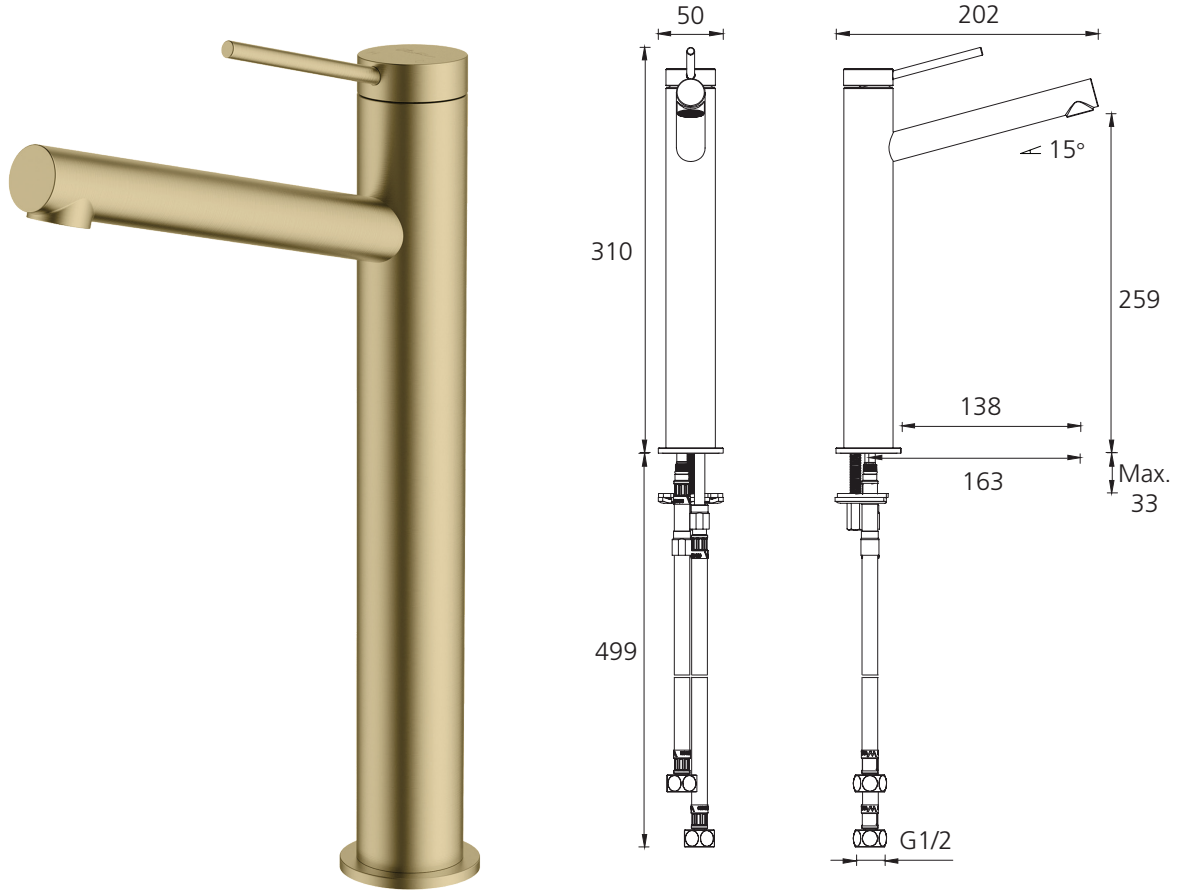

Specifications /

WELS Rating	5 Star, 6L per min
Temperature rating (min / max)	1°C - 65°C
Pressure rating (min / max)	Min 150 kPa - Max 500 kPa
Finish	Classic gold (paint with finger print resistant coating)
Materials	Brass body and zinc handle with SUS handle lever
Cartridge size	25mm
Cartridge type	Ceramic disc cartridge
Product weight	1.2kg
Mixer height	310mm
Water supply	Mains
Warranty	15 years cartridge and body; 5 years finish, seals, tails, fittings, aerators; 1 year labour (refer to oliveri.com.au)
Maintenance and care instructions	All surfaces should be cleaned with mild liquid detergent or soap and water. Do not use cream cleaners or citrus based cleaning products, as they are abrasive. Use of unsuitable cleaning agents may damage the surface. Any damage caused in this way will not be covered by warranty.