

# Winton Compact Dual Shower Round

Brushed Nickel

Product Code: 202987

## WELS Rating Warranty

WELS 3 Stars 9L/min  
20 years - Shower Body, Rail, PVC Coated Hoses, Handpieces, Sliders, Soap Dish and Chrome Finish  
5 years - PVD and Electroplate Finishes  
1 year - Seals and Labour

## Product Specifications

|                               |  |
|-------------------------------|--|
| <b>Colour</b>                 | Brushed Nickel   |
| <b>Finish</b>                 | Electroplated brass and painted ABS  |
| <b>Material</b>               | Brass Rail and diverter<br>ABS Shower Rose, hand piece and slider<br>PVC Hose  |
| <b>Function</b>               | 3 function hand shower   |
| <b>Shower Reach</b>           | 400mm  |
| <b>Diverter Operation</b>     | Twist, 1/4 turn Ceramic Disc   |
| <b>Inclusions</b>             | 1x Compact Dual Shower rail with diverter<br>1x Shower Rose<br>1x Hand shower with hose<br>Fixing kit<br>Install instructions  |
| <b>Country of Manufacture</b> | China  |
| <b>Maintenance &amp; Care</b> | Surfaces should be regularly cleaned with a soft, dampened cloth or sponge with warm, soapy water or mild detergent only. Do not use abrasive brushes, scourers, cleaners or harsh chlorides or chemicals as these can damage the finish |

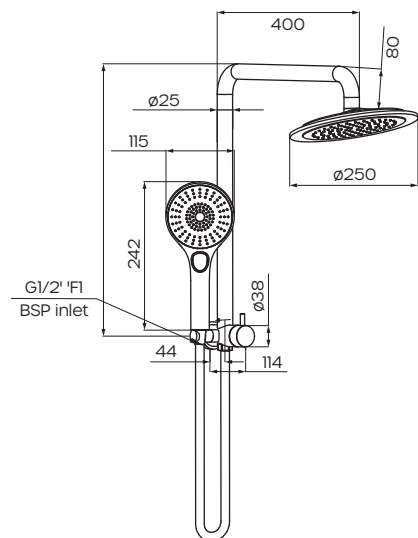

For more information call 1800 729 667 or visit [raymor.com.au](http://raymor.com.au)

© Registered trademark of Tradelink. All dimensions given are approximate and should be checked prior to installation. See [raymor.com.au](http://raymor.com.au) for full warranty details.

**Raymor**<sup>®</sup>