

TEVA

BASIN MIXER

PRODUCT CODE: 152-7700-10
 FINISH: MATTE BLACK
 WELS: 5 STAR - 5.5 LT/MIN

INFORMATION:

TEMPERATURE RATING: MIN 1° - MAX 75°
 PRESSURE RATING: MIN 150 kPa - MAX 500 kPa



AVAILABLE IN:



CHROME BRUSHED MATTE
 NICKEL NICKEL BLACK*

* 1 Year Warranty - Phoenix Builders Matte Black Finish
 FOR MORE INFORMATION VISIT
www.phoenixtapware.com.au

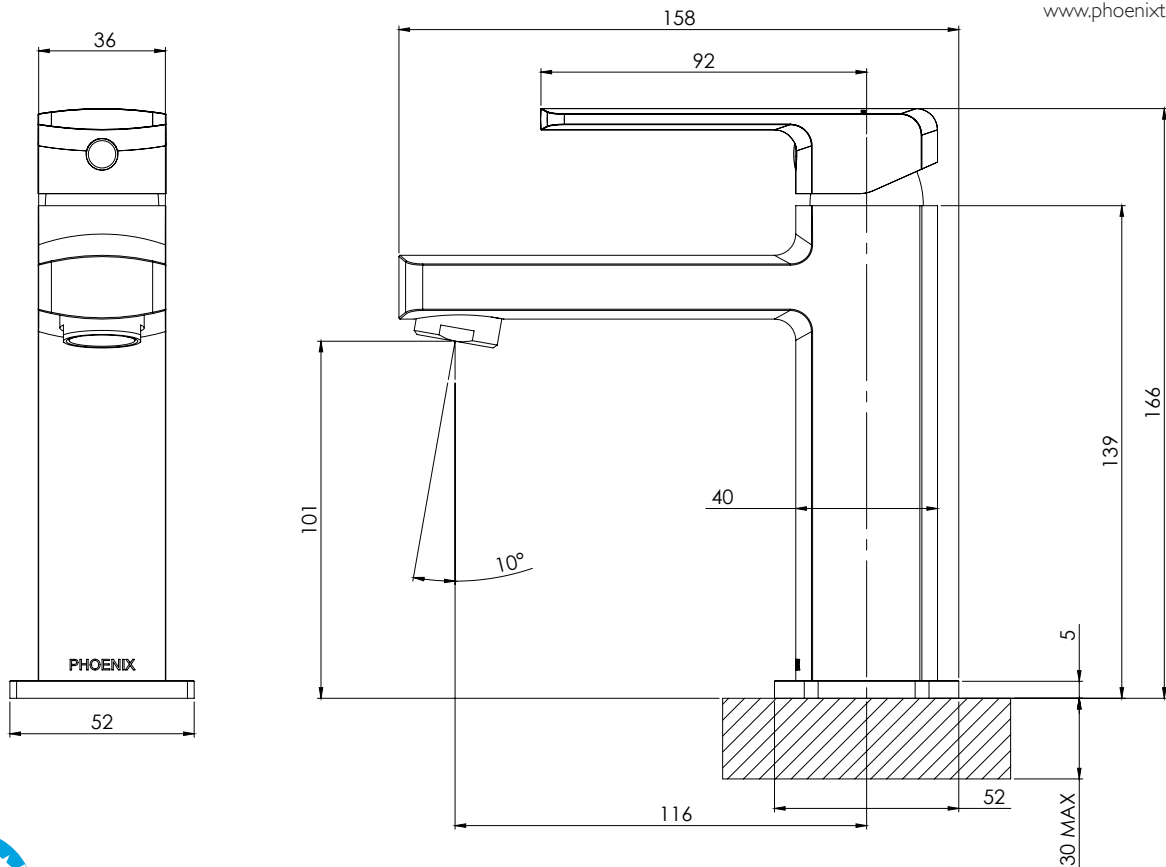

PLEASE [CLICK HERE TO VIEW FULL WARRANTY](#)

While we aim to ensure the specifications shown are correct at time of printing, Phoenix Tapware reserves the right to make modifications without prior notice. Always use the physical product measurements for mark-ups and roughing-in as the line drawing shown may differ from the actual product over time. All measurements are shown in millimetres.

Teva is a Registered Trademark of Phoenix Industries Pty. Ltd.
 V250220

www.phoenixtapware.com.au
 03 9780 4200

TEVA

BASIN MIXER

PRODUCT CODE:

152-7700-10

FINISH:

MATTE BLACK

WELS:

5 STAR - 5.5 LT/MIN



PARTS LIST

1. MIXER BODY
2. SEAT
3. 25MM CARTRIDGE
4. MIXER HANDLE
5. MIXER DOME
6. LOCKNUT
7. DRESS PLATE
8. RETAINER
9. AERATOR
10. SCREW CAP
11. FLEXIBLE HOSE 450MM COLD
12. FLEXIBLE HOSE 450MM HOT
13. M8 THREADED ROD
14. M8 THREADED NUT
15. RUBBER WASHER
16. INDICATOR TAPE
17. GRUB SCREW M4X6
18. MOUNTING PLATE
19. MOUNTING GASKET
20. ORING 19X2.5
21. GRUB SCREW M4X5
22. WASHER
23. GRUB SCREW M5X5

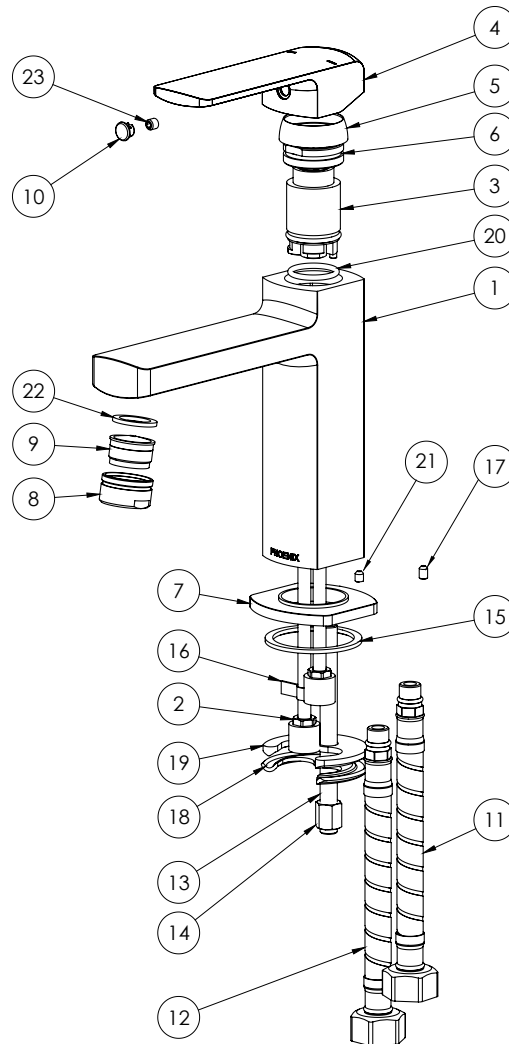

MAINTENANCE AND CARE:

- All surfaces should be cleaned with mild liquid detergent or soap and water.
- Do not use cream cleaners or citrus based cleaning products, as they are abrasive.
- Use of unsuitable cleaning agents may damage the surface. Any damage caused in this way will not be covered by warranty.

 PLEASE [CLICK HERE](#) TO VIEW FULL WARRANTY

While we aim to ensure the specifications shown are correct at time of printing, Phoenix Tapware reserves the right to make modifications without prior notice. Always use the physical product measurements for mark-ups and roughing-in as the line drawing shown may differ from the actual product over time. All measurements are shown in millimetres.

Teva is a Registered Trademark of Phoenix Industries Pty. Ltd.

V250220

www.phoenixtapware.com.au
 03 9780 4200