

# Installation Instructions for Raymor Sinks with Drainer

Item Code 182109/ 182110 / 182111 / 182112

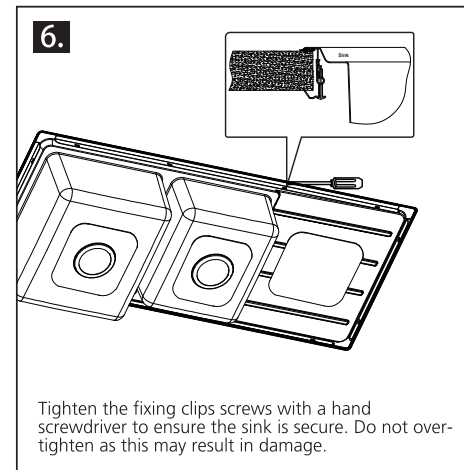
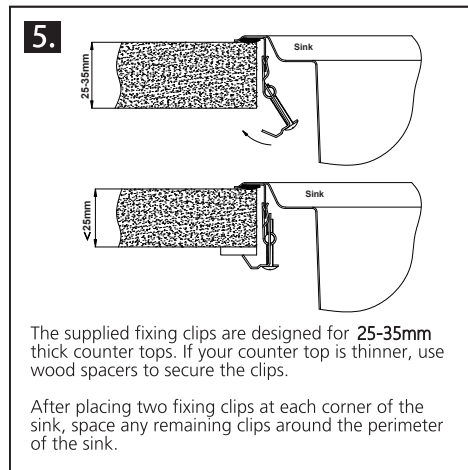
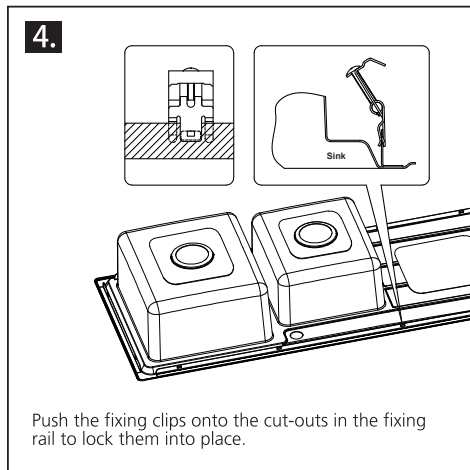
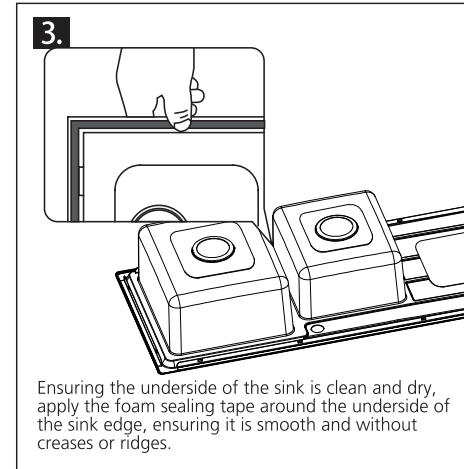
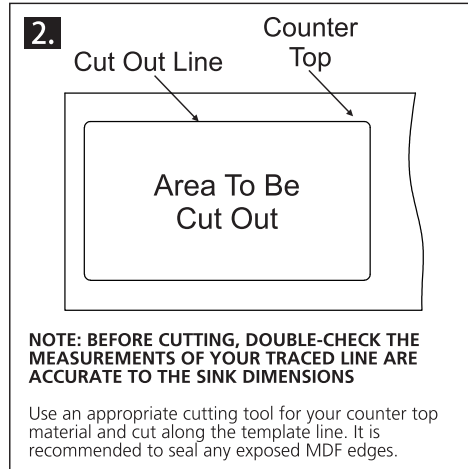
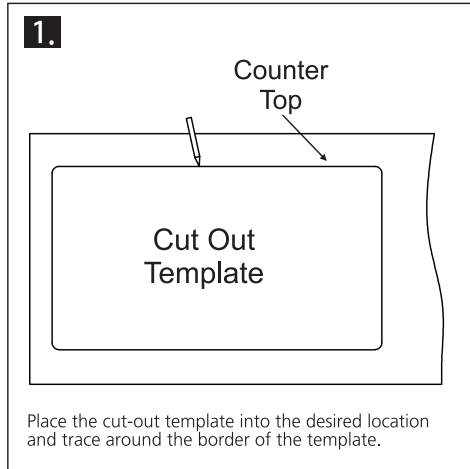

## Care Instructions

For everyday cleaning of the sink, use a mild household detergent suitable for stainless steel. After each use, rinse the sink with warm water and wipe with a soft, dry microfiber cloth.

- Do not use steel wool to clean your sink.
- Wipe in the direction of the grain, along the lines of the bowl and drainer.
- Do not use chemical "silver cleaners", bleaches or detergents containing chlorine or any of its derivatives.
- Water scale can be treated using a mild cream cleaner or white vinegar and a soft cloth. Rinse with water and wipe dry.

## Warning

- If the sink comes into contact with acidic materials, rinse immediately with plenty of water and wipe with a soft, dry cloth.
- Do not leave rusty objects in contact with the sink. Rust can cause staining, cracking or even permanent damage to the sink surface.
- To avoid staining of the surface, do not leave food or other materials with corrosive properties on the sink for an extended period.
- Do not place very hot objects directly onto the sink. Place them onto a board or surface made from wood, silicone, plastic, etc.
- Avoid scraping the sink bowls or drainer surface with utensils.
- Avoid dropping heavy or sharp objects onto the sink surface.

## Warranty:

For continued piece of mind, this product comes with a limited warranty from date of purchase. For full warranty terms and conditions of the warranty including how to claim and your rights as a consumer, please consult [www.raymor.com.au](http://www.raymor.com.au). If you are a consumer as defined under the Australian Consumer Law, our goods come with guarantees that cannot be excluded under the Australian Consumer Law. You are entitled to a replacement or refund for a major failure and compensation for any other reasonably foreseeable loss or damage. You are also entitled to have the goods repaired or replaced if the goods fail to be of acceptable quality and the failure does not amount to a major failure.

Issue Date 05/07/21 Revision Number V1.0

## Warranty Contact Details

Tradelink Pty Ltd  
ABN: 29000003832  
1051 Nudgee Rd  
Banyo QLD 4014  
Phone: 1300 658 277  
Email: [aftersales@tradelink.com.au](mailto:aftersales@tradelink.com.au)