



VULCAN[®]

DUOMAX

FORGED TOUGH FOR THE TRADE

- Fast, easy like-for-like replacement
- Dual handed inlet and outlet fittings
- Mains pressure
- 10 year cylinder warranty¹ on 80L to 400L models

10 YEAR
CYLINDER
WARRANTY¹



VULCAN®
DUOMAX
FORGED TOUGH FOR THE TRADE

MODEL		50L	80L	125L	160L	250L	315L	400L
Vulcan Model code		6D1050/P 6D1050	6D1080	6D1125	6D1160	6D1250	6D1315	6D1400
Tradelink Product code		289058 (2.4kW) 182706 (3.6kW)	182707 (3.6kW)	182708 (1.8kW) 182709 (3.6kW)	182710 (2.4kW) 182711 (3.6kW)	182712 (3.6kW) 182713 (4.8kW)	182714 (3.6kW) 182715 (4.8kW)	288907 (3.6kW) 182716 (4.8kW)
Hot Water Delivery	Litres	50	80	125	160	250	315	400
kW Rating	1.8	—	—	✓	—	—	—	—
	2.4	✓ with plug	—	—	✓	—	—	—
	3.6	✓	✓	✓	✓	✓	✓	✓
	4.8	—	—	—	—	✓	✓	✓
Relief Valve Setting	kPa	1000	1000	1000	1000	1000	1000	1000
Expansion Control Valve	kPa	850	850	850	850	850	850	850
Max Water Supply Pressure:								
with ECV	kPa	680	680	680	680	680	680	680
without ECV	kPa	800	800	800	800	800	800	800
Water Connections		Rp ³ / ₄	Rp ³ / ₄	Rp ³ / ₄	Rp ³ / ₄	Rp ³ / ₄	Rp ³ / ₄	Rp ³ / ₄
Dimensions								
A	mm	695	875	1250	1610	1395	1640	1840
B	mm	400	461	480	480	640	640	690
C	mm	425	485	500	500	680	680	730
D	mm	397	475	853	1332	1112	1317	1479
E	mm	142	194	194	104	73	113	121
F	mm	60	112	112	66	103	103	105
H	degrees	26	22	22	23	32	32	30
J	degrees	59	60	60	58	88	88	83
M	degrees	—	—	—	—	92	92	97
K	mm	436	496	515	515	—	—	—
Approx. Weight (packaged)	kg	26	32	45	59	82	97	120

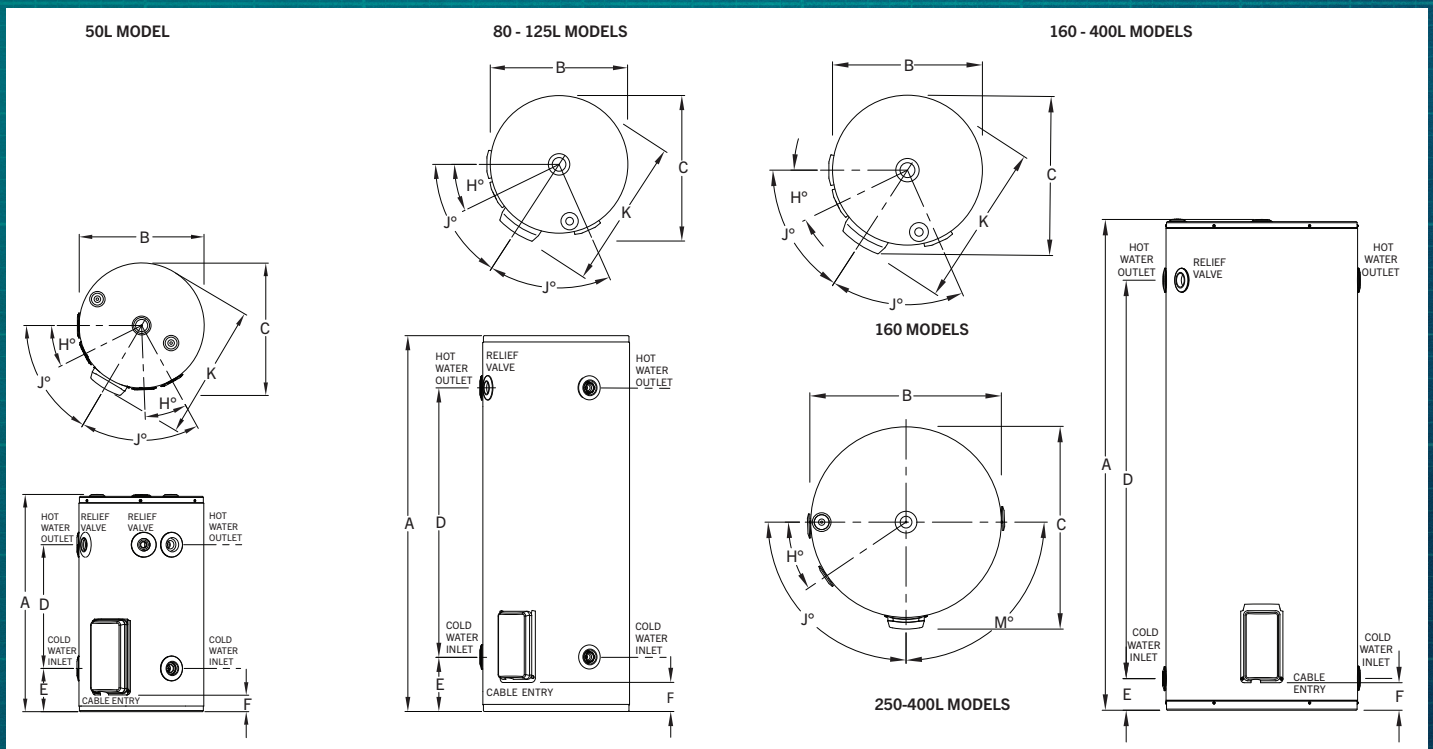

Vulcan MKT Spec sheet March 2023

1. Warranty for Domestic (non-Commercial) installations. 7 Years on Cylinder, 1 Year Labour on Cylinder, 1 Year Parts and Labour (50L). 10 Years on cylinder, 1 Year Labour on Cylinder, 1 Year Parts and Labour (80L, 125L, 160L, 250L, 315L and 400L). Conditions apply. See the Owner's Guide and Installation Instructions or view online at www.vulcan.com.au

Available at

Tradelink®