

PINA

WALL BASIN / BATH MIXER SET 180MM TRIM KIT ONLY

PRODUCT CODE:	153-7812-10
FINISH:	MATTE BLACK
WELS:	5 STAR - 6.0 LT/MIN
INFORMATION:	
TEMPERATURE RATING:	MIN 1° - MAX 75°
PRESSURE RATING:	MIN 150 kPa - MAX 500 kPa



AVAILABLE IN:



CHROME BRUSHED NICKEL MATTE BLACK

* 1 Year Warranty - Phoenix Builders Matte Black Finish
 FOR MORE INFORMATION VISIT
www.phoenixtapware.com.au

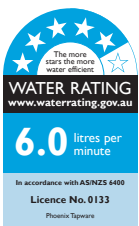
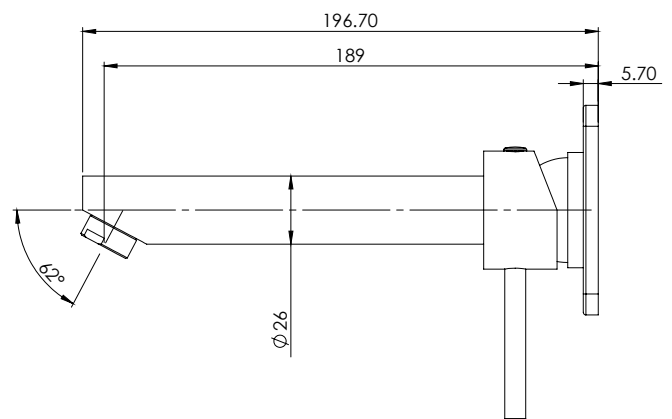
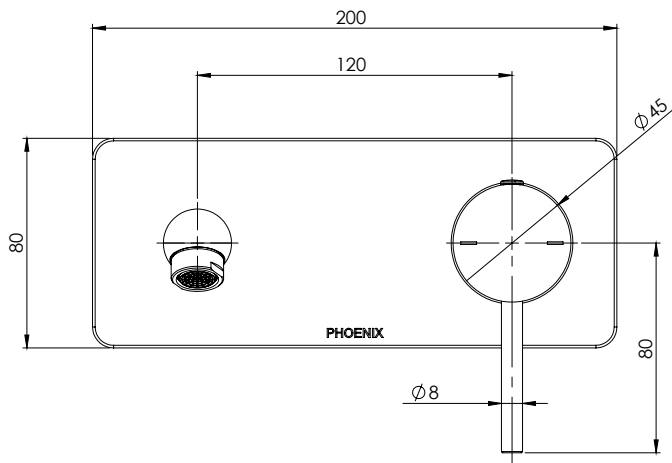
 PLEASE [CLICK HERE](#) TO VIEW FULL WARRANTY

While we aim to ensure the specifications shown are correct at time of printing, Phoenix Tapware reserves the right to make modifications without prior notice. Always use the physical product measurements for mark-ups and roughing-in as the line drawing shown may differ from the actual product over time. All measurements are shown in millimetres.

Pina is a Registered Trademark of Phoenix Industries Pty. Ltd.

V260220

www.phoenixtapware.com.au
 03 9780 4200

PINA

WALL BASIN / BATH MIXER SET 180MM TRIM KIT ONLY

PRODUCT CODE: 153-7812-10
 FINISH: MATTE BLACK
 WELS: 5 STAR - 6.0 LT/MIN



PARTS LIST

1. BACK PLATE
2. 180MM OUTLET
3. WASHER
4. HANDLE
5. SCREW CAP
6. GRUB SCREW M5X5
7. AERATOR 7LT/MIN
8. MAX FLOW AERATOR
9. RETAINER
10. GASKET

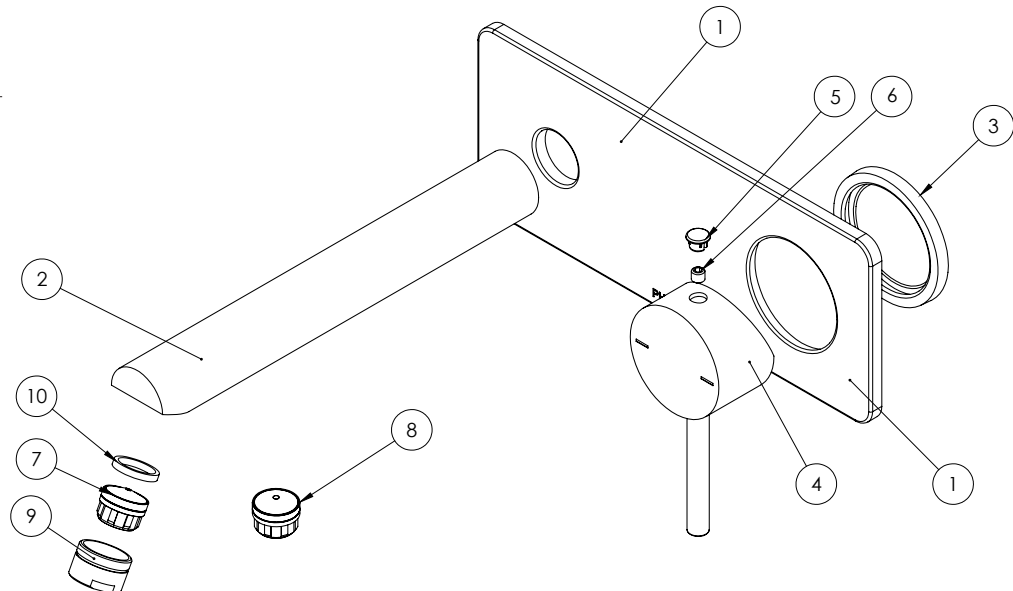

MAINTENANCE AND CARE:

- All surfaces should be cleaned with mild liquid detergent or soap and water.
- Do not use cream cleaners or citrus based cleaning products, as they are abrasive.
- Use of unsuitable cleaning agents may damage the surface. Any damage caused in this way will not be covered by warranty.

PLEASE [CLICK HERE TO VIEW FULL WARRANTY](#)

While we aim to ensure the specifications shown are correct at time of printing, Phoenix Tapware reserves the right to make modifications without prior notice. Always use the physical product measurements for mark-ups and roughing-in as the line drawing shown may differ from the actual product over time. All measurements are shown in millimetres.

Pina is a Registered Trademark of Phoenix Industries Pty. Ltd.

V260220

www.phoenixtapware.com.au
03 9780 4200