

ARLO

BASIN MIXER

PRODUCT CODE: 151-7700-40
FINISH: BRUSHED NICKEL
WELS: 5 STAR - 5.5 LT/MIN

INFORMATION:

TEMPERATURE RATING: MIN 1° - MAX 75°
PRESSURE RATING: MIN 150 kPa - MAX 500 kPa



AVAILABLE IN:

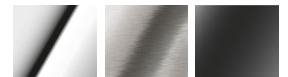

CHROME BRUSHED NICKEL MATTE BLACK

* 1 Year Warranty - Phoenix Builders Matte Black Finish
 FOR MORE INFORMATION VISIT
www.phoenixtapware.com.au

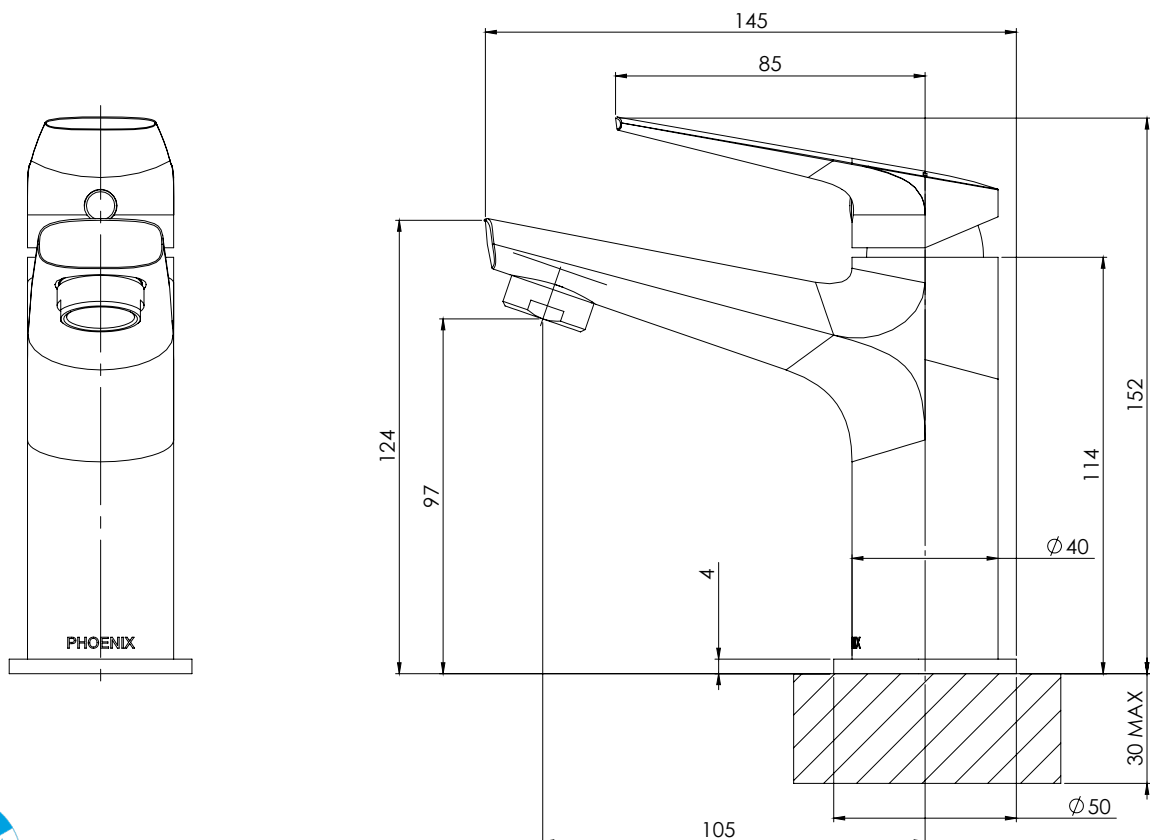

PLEASE [CLICK HERE TO VIEW FULL WARRANTY](#)

While we aim to ensure the specifications shown are correct at time of printing, Phoenix Tapware reserves the right to make modifications without prior notice. Always use the physical product measurements for mark-ups and roughing-in as the line drawing shown may differ from the actual product over time. All measurements are shown in millimetres.

Arlo is a Registered Trademark of Phoenix Industries Pty. Ltd.

V12022020

www.phoenixtapware.com.au
 03 9780 4200

ARLO

BASIN MIXER

PRODUCT CODE: 151-7700-40
FINISH: BRUSHED NICKEL
WELS: 5 STAR - 5.5 LT/MIN



PARTS LIST

1. MIXER BODY
2. CARTRIDGE SEAT
3. 25MM CARTRIDGE
4. MIXER HANDLE
5. DOME
6. LOCKNUT
7. DRESS RING
8. RETAINER
9. AERATOR
10. SCREW CAP
11. FLEXIBLE HOSE 450MM COLD
12. FLEXIBLE HOSE 450MM HOT
13. M8 THREADED NUT
14. M8 TREADED ROD
15. MOUNTING PLATE
16. MOUNTING GASKET
17. RUBBER WASHER
18. INDICATOR TAPE
19. GRUB SCREW M4X6
20. O-RING 19X2.5
21. WASHER
22. GRUB SCREW M5X6

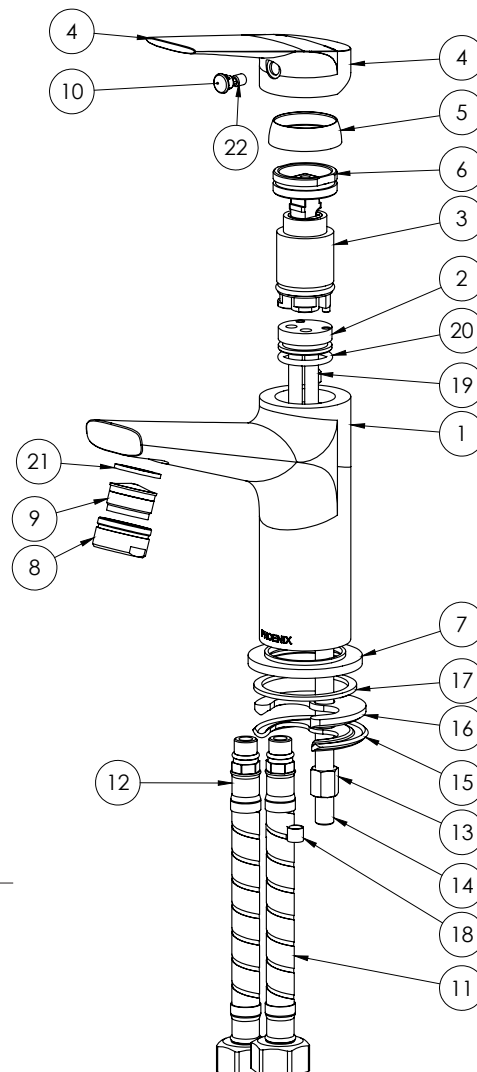

MAINTENANCE AND CARE:

- All surfaces should be cleaned with mild liquid detergent or soap and water.
- Do not use cream cleaners or citrus based cleaning products, as they are abrasive.
- Use of unsuitable cleaning agents may damage the surface. Any damage caused in this way will not be covered by warranty.

PLEASE [CLICK HERE TO VIEW FULL WARRANTY](#)

While we aim to ensure the specifications shown are correct at time of printing, Phoenix Tapware reserves the right to make modifications without prior notice. Always use the physical product measurements for mark-ups and roughing-in as the line drawing shown may differ from the actual product over time. All measurements are shown in millimetres.

Arlo is a Registered Trademark of Phoenix Industries Pty. Ltd.

V12022020

www.phoenixtapware.com.au
 03 9780 4200