

Edge II Double Towel Rail 785mm

Brushed Nickel

Product Code: 203013

Warranty

10 years - main body, chrome plated finish & fittings

5 years - PVD & electroplate finishes

1 year - seals & labour

Product Specifications

Colour	Brushed Nickel
Material	Brass
Width	785mm
Height	24mm
Depth	120mm
Finish	Electroplated
Inclusions	Product Fixing kit Install instructions
Country of Manufacture	China

Maintenance & Care	Surfaces should be regularly cleaned with a soft, dampened cloth or sponge with warm, soapy water or mild detergent only. Do not use abrasive brushes, scourers, cleaners or harsh chlorides or chemicals as these can damage the finish
-------------------------------	--

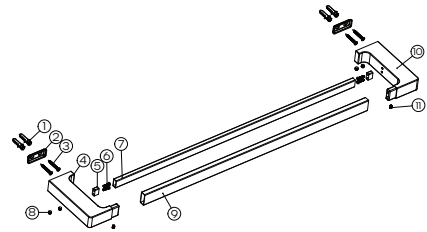
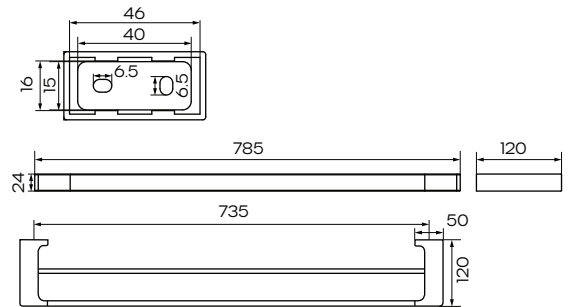

For more information call 1800 729 667 or visit raymor.com.au

© Registered trademark of Tradelink. All dimensions given are approximate and should be checked prior to installation. See raymor.com.au for full warranty details.

Raymor[®]