

Boston II Hand Towel Rail

Brushed Nickel

Product Code: 203022

Warranty

10 years - main body, chrome plated finish & fittings

5 years - PVD & electroplate finishes

1 year - seals & labour



Product Specifications

Colour	Brushed Nickel
Material	Brass
Width	239mm
Height	52mm
Depth	91.5mm
Finish	Electroplated
Inclusions	Product Fixing kit Install instructions
Country of Manufacture	China

Maintenance & Care

Surfaces should be regularly cleaned with a soft, dampened cloth or sponge with warm, soapy water or mild detergent only. Do not use abrasive brushes, scourers, cleaners or harsh chlorides or chemicals as these can damage the finish

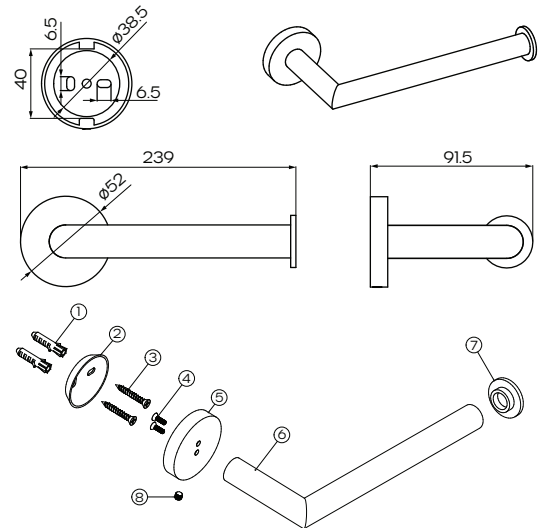

For more information call 1800 729 667 or visit raymor.com.au

© Registered trademark of Tradelink. All dimensions given are approximate and should be checked prior to installation. See raymor.com.au for full warranty details.

Raymor[®]