

# Projix Glass Shelf

Brushed Nickel

Product Code: 203041

## Warranty

10 years - main body, chrome plated finish & fittings

5 years - PVD & electroplate finishes

1 year - seals & labour



## Product Specifications

<b>Colour</b>	Brushed Nickel
<b>Material</b>	Zinc, 201 Stainless Steel and frosted glass
<b>Width</b>	610mm
<b>Height</b>	57mm
<b>Depth</b>	160mm
<b>Finish</b>	Electroplated
<b>Inclusions</b>	Product Fixing kit Install instructions
<b>Country of Manufacture</b>	China
<b>Maintenance &amp; Care</b>	Surfaces should be regularly cleaned with a soft, dampened cloth or sponge with warm, soapy water or mild detergent only. Do not use abrasive brushes, scourers, cleaners or harsh chlorides or chemicals as these can damage the finish

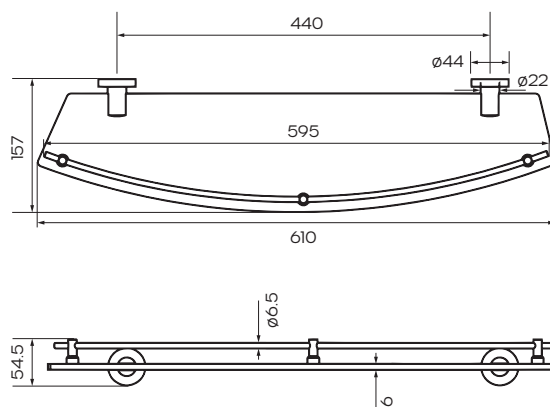

For more information call 1800 729 667 or visit [raymor.com.au](http://raymor.com.au)

© Registered trademark of Tradelink. All dimensions given are approximate and should be checked prior to installation. See [raymor.com.au](http://raymor.com.au) for full warranty details.

**Raymor**<sup>®</sup>