

Winton Rail Shower Brushed Nickel

Product Code: 286413

Product Specifications.

WELS rating	WELS 3 Star 9.0L/min
WELS Registration No.	
Warranty	20 years – main brass body, wall elbow, shower arm, shower rail, PVC coated hose, showerhead, handpiece, slide bracket, diverter assembly, soap dish, and chrome plated finish 5 years - PVD and electroplate finishes 1 year - seals and labour
Colour	Brushed Nickel
Finish	Electroplated, painted ABS
Installation Type	Wall mount
Material	Brass Rail ABS Shower Rose, hand piece and slider PVC Hose
Shower Type	Rail Shower
Function	3 function hand shower
Rail Length	720mm
Rail Diameter	25mm
Hand Shower Diameter	110mm



Inclusions	Rail Shower Soap dish Installation Instructions
-------------------	---

Maintenance & Care	Clean using a soft sponge or cloth with warm soapy water or detergent. Never use abrasive brushes or scourer pads to clean products. Rinse with water immediately after using any cleaning solution
-------------------------------	---

For more information call 1800 BATHROOM (1800 228 476) or visit raymor.com.au

© Registered trademark of Tradelink. All dimensions are in millimetres. Dimensions are approximate and should be checked against the physical product before installation. Changes may be made to this specification without notice due to our commitment to continual improvement. See raymor.com.au for full warranty details.
All dimensions in mm.

Version 1

raymor

Winton Rail Shower Brushed Nickel

Product Code: 286413

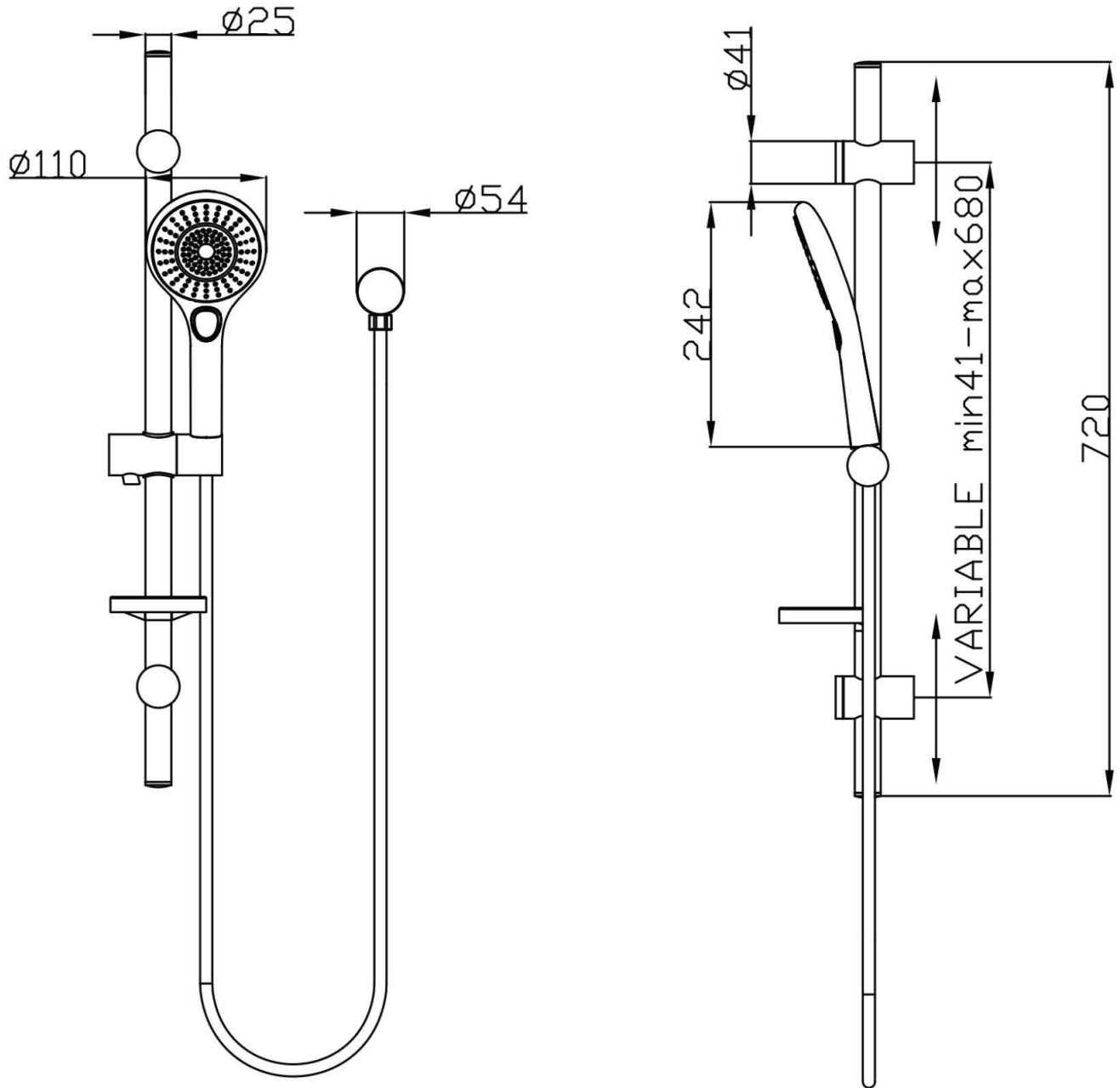

For more information call 1800 BATHROOM (1800 228 476) or visit raymor.com.au

© Registered trademark of Tradelink. All dimensions are in millimetres. Dimensions are approximate and should be checked against the physical product before installation. Changes may be made to this specification without notice due to our commitment to continual improvement. See raymor.com.au for full warranty details.
All dimensions in mm.

Version 1

raymor