

Vertical Black Glass Wall mounted 90cm Rangehood

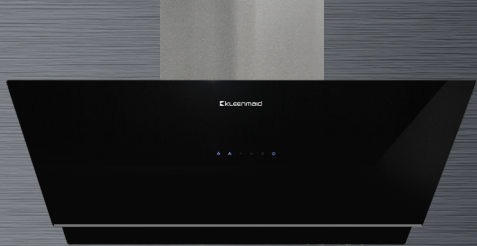

Model: RHGV90

- Under glass ESTC Electronic Sensor touch Controls
- Dual blade Black Krystal glass construction with stainless steel flue
- Optional carbon filters available for recirculating installation - ORDER KMCF200
- 4 extraction speeds including Boost
- Two 1.5w LED lamps with on and off soft fade
- Dual level venting to maximise performance
- Twin access washable 5-layer aluminium grease filters
- Low energy motor for reducing power consumption
- 12% more powerful performance 900 m³/h
- 16% quieter 47dbA with Kleenmaid's Whisper technology
- Automatic run-on timer
- Non-return protection for external air
- 150mm diameter air venting for superior air flow
- This appliance comes with a 10A plug and cord ready for plug in and use



Whisper



Low Energy
Motor



10A Plug
Ready to use

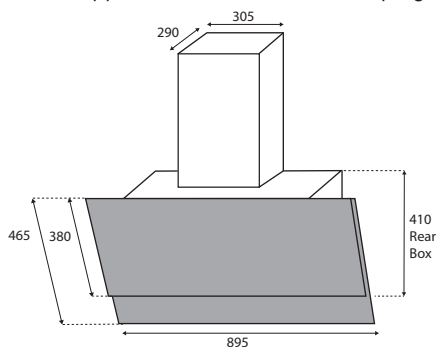

These dimensions are provided as a general guide only and should not be used for designing or constructing cabinetry or for installation.

To obtain full installation instructions for this appliance go to kleenmaid.com.au and click on User Care Manuals, top right.



Fineline :0103467

J12761_01

Level 2, 204 Botany Road, Alexandria NSW, 2015
P: 02 9310 1207 • E: support@kleenmaid.com.au
www.kleenmaid.com.au

KLEENMAID
The best you can own