

Shower Arm Ceiling Mount Straight Round Flange & Rail 300mm Brushed Nickel.

Product Code: 290635



Product Specifications.

Warranty	20 years - main brass body, wall elbow, shower arm, shower rail, PVC coated hose, showerhead, handpiece, slide bracket, diverter assembly, soap dish, and chrome plated finish 5 years - PVD and electroplate finishes 1 year - seals and labour
-----------------	--

Colour Brushed Nickel

Finish Electroplating

Installation Type Ceiling mount

Material Brass

Arm Design Dropper

Rail Shape Round

Inlet Connection 1/2" BSP Female

Outlet Connection 1/2" BSP Male

Reach

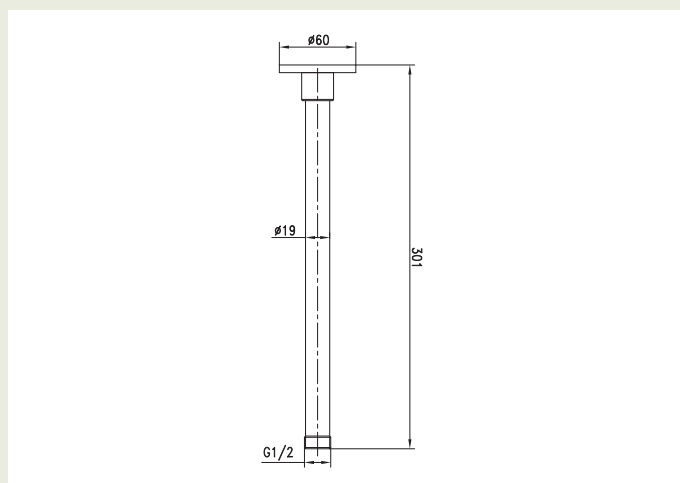

Length 300mm

Inclusions Arm with flange
Install instructions

Maintenance & Care Clean using a soft sponge or cloth with warm soapy water or detergent. Never use abrasive brushes or scourer pads to clean products. Rinse with water immediately after using any cleaning solution

For more information call 1800 BATHROOM (1800 228 476) or visit raymor.com.au

© Registered trademark of Tradelink. All dimensions are in millimetres. Dimensions are approximate and should be checked against the physical product before installation. Changes may be made to this specification without notice due to our commitment to continual improvement. See raymor.com.au for full warranty details.

All dimensions in mm.

Version 1

raymor