

# Munich

**MU006WH**

Wall Hung Basin with Shelf (Right Hand)

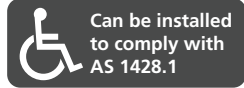

All dimensions in mm

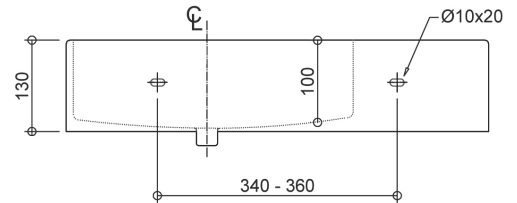
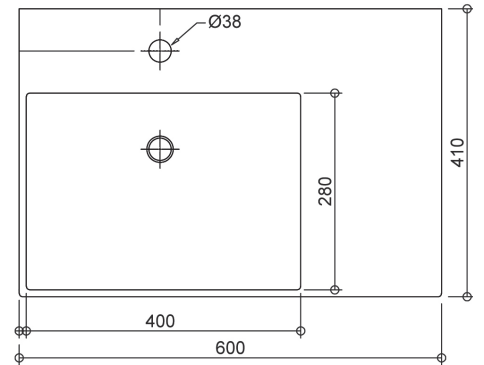

## Specifications /

|  |  |
|--|--|
| <b>Tap holes</b>                         | 1 tap hole   |
| <b>Waste outlet</b>                      | Pop up waste sold separately   |
| <b>Overflow</b>                          | Included (with plastic chrome plated overflow ring)  |
| <b>Colours</b>                           | White  |
| <b>Basin size</b>                        | 600W x 410H x 130D mm  |
| <b>Bowl size</b>                         | 400W x 280H x 100D mm  |
| <b>Bowl capacity</b>                     | 11.2L  |
| <b>Material</b>                          | Vitreous china   |
| <b>Installation</b>                      | Wall hung  |
| <b>Weight</b>                            | 17.0kg   |
| <b>Commercial warranty</b>               | 10 years replacement parts, 1 year labour (refer to oliveri.com.au)  |
| <b>Maintenance and care instructions</b> | All surfaces should be cleaned with mild liquid detergent or soap and water. Do not use cream cleaners or citrus based cleaning products, as they are abrasive. Use of unsuitable cleaning agents may damage the surface. Any damage caused in this way will not be covered by warranty. |