

# Installation Instructions

## 285814/285887/285894 SINK MIXER EDGE II 5STAR LF

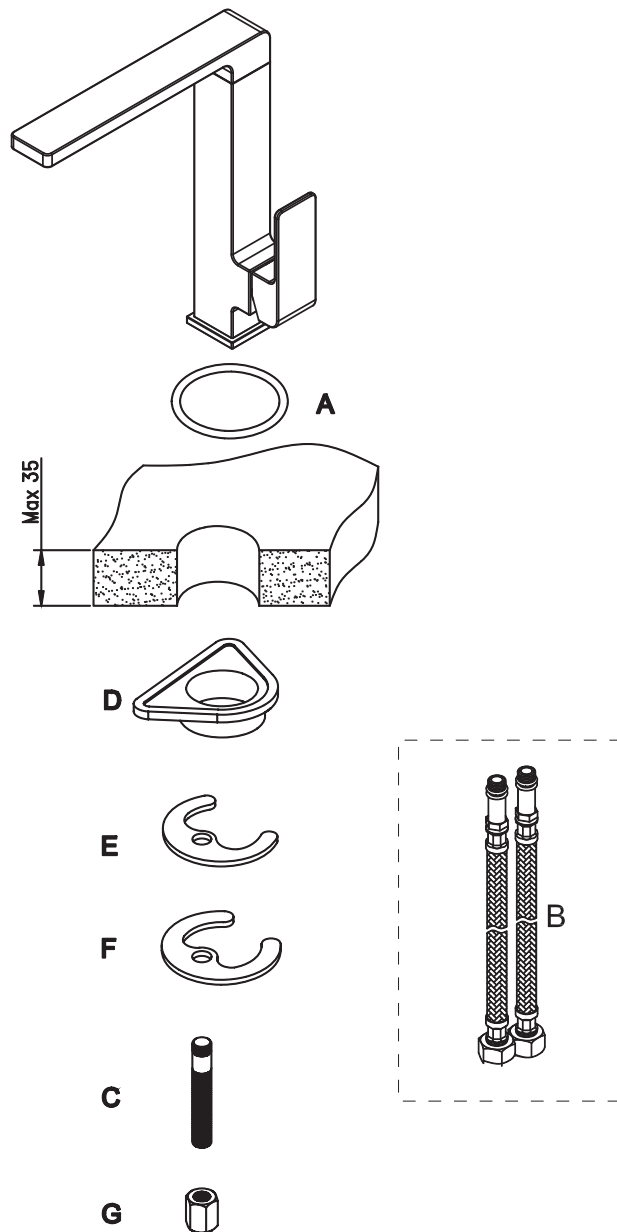

### Important Information

This Product is to be installed by a licensed plumber, installation must comply with the AS/NZS 3500 series of Standards and relevant plumbing codes. Isolating stop taps are recommended to be fitted to the hot and cold inlet connections. Please leave this document with the Product after installation. This product complies with the Lead Free requirements of the National Construction Code Volume 3.

Please ensure that the lines are flushed prior to installation as contaminants in the water can damage the ceramic disc cartridge, O-rings and flow regulators and affect the performance of the Product. The WELS compliant aerator has been pre-assembled into the outlet (where applicable). To comply with WELS the flow regulated aerator must remain in place and be tightened to prevent removal by hand.

Before installation, remove Product from packaging and check the Product matches what you have ordered, is complete with all parts (per exploded drawing) and is not damaged. **If the Product is incorrect, damaged or missing parts DO NOT install and return to store** with proof of purchase for a refund or replacement. Installed Products are warranted for genuine manufacturing defects arising in your Product during the course of normal domestic or commercial use for the term of the warranty period. Our manufacturer's warranty does not cover Product which are incorrect or have been installed with pre-existing damage or missing parts.

### Pressure & Temperatures

- Maximum Hydrostatic Pressure - 500kPa. (per AS/NZS3500.1 (Clause 3.3.4) which states "The maximum static pressure at any outlet, other than a fire service outlet, within a building shall not exceed 500kPa." **NB.** Pressures above 500kPa can cause damage from water hammer, reduced life of appliances, taps and fittings, and cause excessive noise in the system.
- Minimum Hydrostatic Pressure - 100kPa. This Product may not be suitable for use with a gravity fed water supply or with continuous flow or instantaneous hot water systems.
- Maximum operating temperature - 65°C.

### Installation Instructions

**NB.** A single 35mm Hole is required in the mounting surface. The maximum mounting surface thickness cannot exceed 35mm.

- Ensuring bench Sealing washer(A) is in place on base of Mixer, firmly screw the Mixer tails (B) into base of the Mixer, being careful to avoid damage to the o-ring seals, The Mixer Tails are colour coded, Red for hot and Blue for cold, the Mixer base inlet holes are stamped with 'H' for Hot and 'C' for cold.
- Screw Threaded Rod (C) into base of Mixer.
- Feed the Mixer Tails (B) through the Mounting surface, alternating each end and position the Mixer on the mounting surface ensuring the sealing washer (A) is in position, covering the hole in the mounting surface. Feed both Mixer tails through the Stabiliser plate (D), alternating each end (where supplied).
- Slide Rubber Horse Shoe (E) onto Threaded Rod (C) followed by Metal Horse shoe Plate (F). **NB.** The Mixer Tails should be positioned towards the user and the Fixing bolt to the back.
- Using Fixing Nut (G), tighten Mixer to mounting surface. An appropriately sized tube spanner is strongly recommended.
- Connect Mixer tails to Mains Water supply line. We recommend the following guidelines when fitting flexible hoses:

DO NOT KINK	DO NOT STRETCH	DO NOT TWIST
Minimum Bend Radius=10mm	As a guide, a 300mm long hose should span a direct distance of 260-280mm between mixer base and plumbing supply connection	Avoid Twisting the hose. It should not be necessary to apply excessive force to the end fittings in order to obtain a watertight seal.

### Hose Specification & Scope of Use

- Nominal hose diameter (ID).....DN8
- Minimal bend radius.....10mm
- Tightening torque.....10Nm
- Static water pressure.....up to 1400kPa
- Water temperature.....up to 90°C
- Potable water.....6.5-8.5pH

- Test for correct operation and check all connections for leaks.

### To the End User

- Ensure Mixer tails are not exposed to abrasives, corrosive agents or similar.
- Check the flexible hose connector regularly and replace if damaged or worn.
- If not used for an extended period, flush lines for several minutes before use.