

SS316L 35mm Premium Universal Shower Mixer

Nero

Body Only

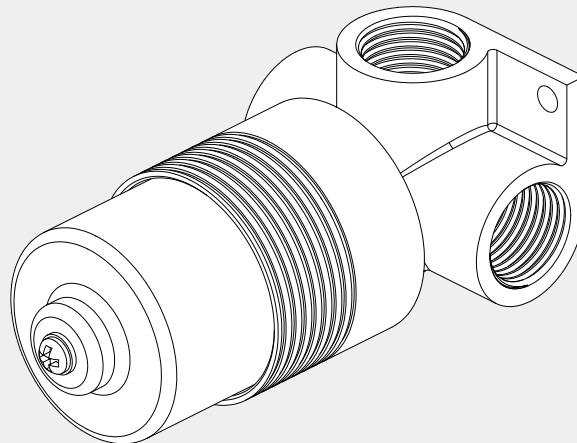

Versions:202405

Top/Back

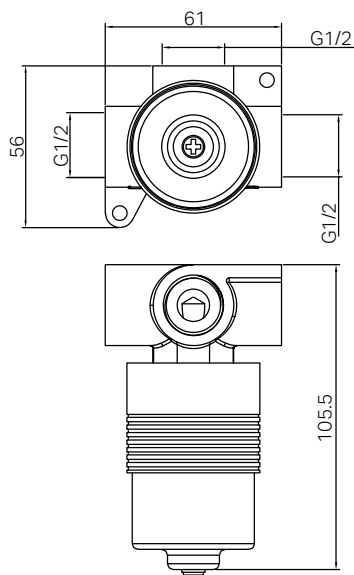

Specifications

SKU

NRUB006

Watermark License

WM-060073

Temperature Rating

Min 1°C-Max 75°C

Pressure Rating

Min 150kpa - Max 500kpa

Packaging Includes

1x Mixer Body

*Dimensions are nominal measurements only.
**Only compatible with all SS316L bath / shower mixers.

Installation Instruction For Body Only

GENERAL INSTRUCTIONS:

- This product must be installed by a licensed plumber. Ensure that your plumbing installation conforms to the Australian/New Zealand Standard AS/NZS 3500.
- All pipework must be thoroughly flushed prior to the installation of the mixer. In-line filters must be fitted on both hot and cold supplies to prevent foreign particles from damaging the ceramic cartridge.
- All outlets used primarily for personal hygiene must deliver water at a safe temperature in accordance with regional regulations.

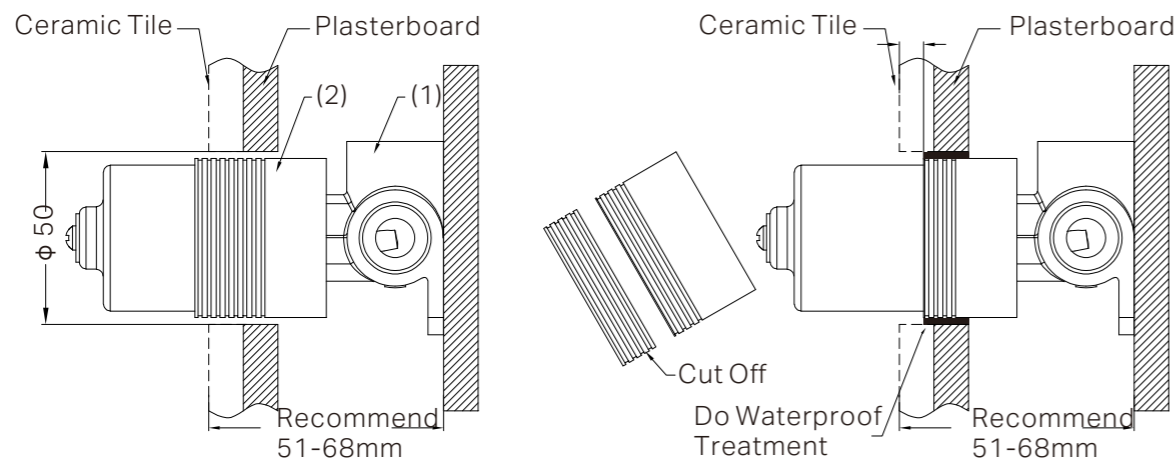

1. Secure the mixer body (1) to the nogging, ensuring an installation depth of 51-68mm from the nogging to the ceramic tile.
Note: Do not remove the plastic sleeve (2) from the mixer body.
2. Connect the cold and hot water supply lines and perform a leak test.
3. Drill a $\phi 50$ mm hole in the plasterboard for mixer body installation, and then position the plasterboard as shown in the above image.

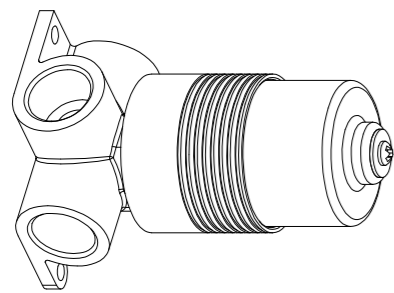

4. Mark the plastic sleeve (2) 4-7 mm from the ceramic tile surface to the body and waterproof the gap between the plasterboard and body.
5. Remove the self-tapping screw, washer, and plastic sleeve, then cut the sleeve at the marked point.
6. Reattach the self-tapping screw, washer, and plastic sleeve.

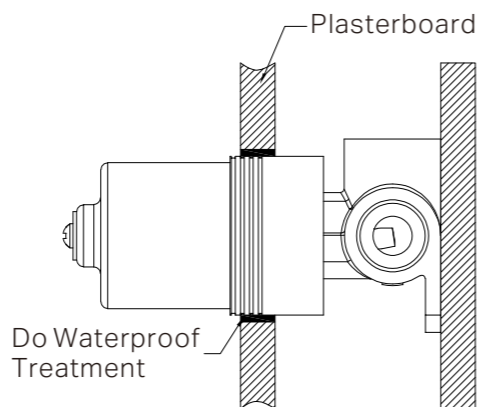

7. Waterproof the gap between the plasterboard and body.

Installation Instruction For Trim Kits Only

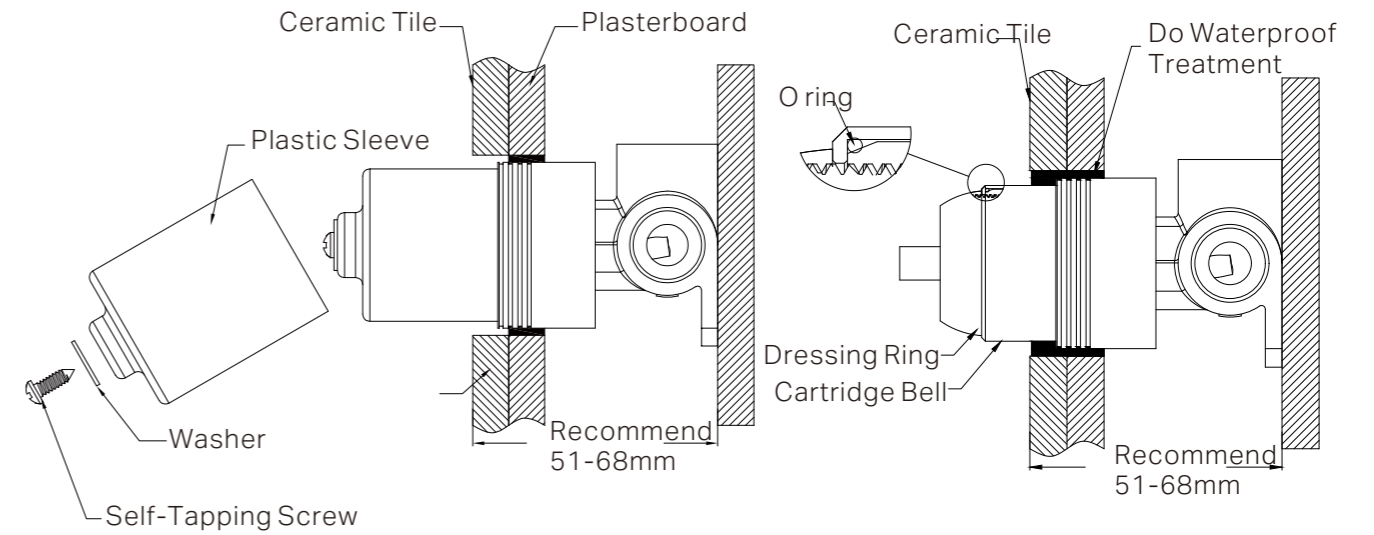

1. Drill a $\phi 50$ mm hole in the ceramic tile, then position it as shown in the above diagram.
2. Undo the self-tapping screw, washer, plastic sleeve.

3. Insert the O ring to the cartridge bell groove, and slide the dressing ring onto cartridge.
4. Apply waterproof treatment to the area in the diagram above.
5. Tighten the dressing ring on the cartridge bell.

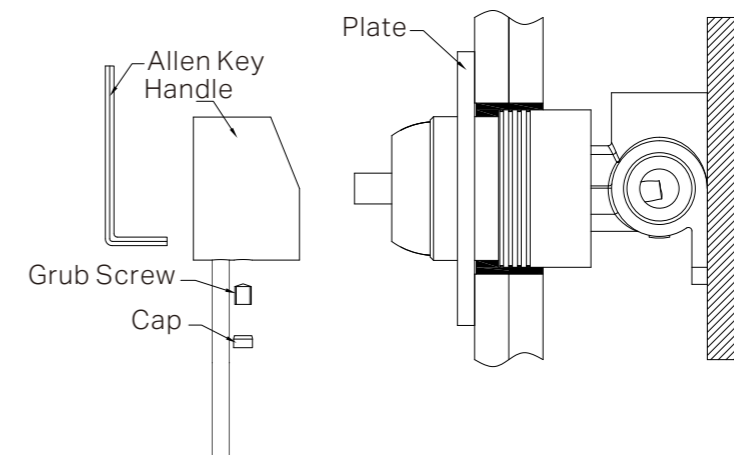

6. Slide the backplate onto the wall.
7. Position the handle, tighten it with a grub screw using an Allen key, and cap the grub screw hole.

MAINTENANCE AND CARE:

- Regularly check the mixer and connections for signs of wear or leaks.
- Clean the tap with mild soapy water to maintain its appearance, avoiding harsh chemicals and abrasive materials that may damage the finish.

FINAL INSPECTION:

- Ensure the tap operates smoothly and that there are no leaks at the connections.
- Clean the area and the newly installed tap with a soft cloth to remove any installation residues.

Nero

