

90cm Stainless Steel and Black Glass Island Rangehood



Model: RHCKL92

- Kleenmaid's unique No Touch Gesture Control operation
- Optional carbon filters available for recirculating installation - Order KMCF200
- 4 extraction speeds including Boost
- Four 1.5w LED lamps
- Washable 5-layer aluminium grease filters
- Low energy BLDC motor for reducing power consumption with 10 Year warranty
- Powerful performance 900 m³/h
- 44dbA with Kleenmaid's Whisper technology
- Non-return protection for external air
- 150mm diameter air venting for superior air flow
- This appliance comes with a 10A plug and cord ready for plug in and use



Whisper



Low Energy
BLDC Motor



10A Plug
Ready to use

**B.L.D.C
MOTOR**

10 year
warranty

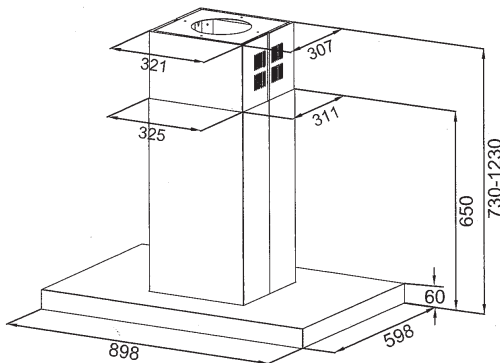

These dimensions are provided as a general guide only and should not be used for designing or constructing cabinetry or for installation.

To obtain full installation instructions for this appliance go to kleenmaid.com.au and click on User Care Manuals, top right.

Level 2, 204 Botany Road, Alexandria NSW, 2015
P: 02 9310 1207 • E: support@kleenmaid.com.au
www.kleenmaid.com.au



I/N: TBA

J14105_03

KLEENMAID
The best you can own