

Tono Care

WALL BASIN

RB5042

Left Bowl

No Tap Hole **RB5042L**

1 Tap Hole **RB5042L-1**

Right Bowl

No Tap Hole **RB5042R**

1 Tap Hole **RB5042R-1**

Left Bowl with shroud

No Tap Hole **RB5042LS**

1 Tap Hole **RB5042LS-1**

Right Bowl with shroud

No Tap Hole **RB5042RS**

1 Tap Hole **RB5042RS-1**

- Contemporary thin rim design
- Integrated shelf for extra storage space
- Shroud for concealing pipework
- Gloss white vitreous china
- Built-in overflow
- Requires 32 mm overflow waste (not included)
- Chrome overflow ring and wall mounting bolts included
- Can install for AS 1428.1:2021 Accessible compliance

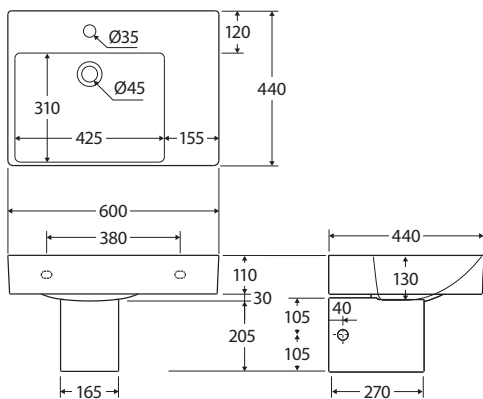

CHECK GOODS THOROUGHLY BEFORE INSTALLATION

Installation of received goods that are damaged, warped or faulty will void warranty. Ensure all items meet your plumbing requirements.



PLEASE LEAVE THIS GUIDE WITH THE OWNER



**AS 1428.1
ACCESSIBLE
COMPLIANT**



RB5042L-1 model shown



RB5042LS-1 model shown

Installation Instructions

PLEASE READ CAREFULLY BEFORE INSTALLATION

The fixings supplied are suitable for solid masonry walls only. Plasterboard or stud walls may require specialist fixings (not supplied).

CAUTION: Care should be taken when drilling walls and floors to avoid any sunken electrical wires or water pipes.

FOR OTHER WALL CONSTRUCTION SYSTEMS USE SUITABLE FIXING METHOD.

All installations should be carried out by a qualified tradesman in compliance with the National Plumbing & Drainage Code and any State or Local Authority Regulations, in accordance with AS/NZS 3500 series of standards and AS/NZA 6400. All measurements are in millimetres and are subject to change without notice. For ceramic products, please allow +/- 10 mm tolerance for manufacturing variance. Please refer to fienza.com.au for the latest product specification.

Basin Installation with Fixing Kit

1. Mark out the installation height and the centre line of the basin on the finished wall at the recommended height as shown and prepare water inlet and outlet connections.

Note: Installation height for AS 1428.1 compliance must be at 830mm to be compliant

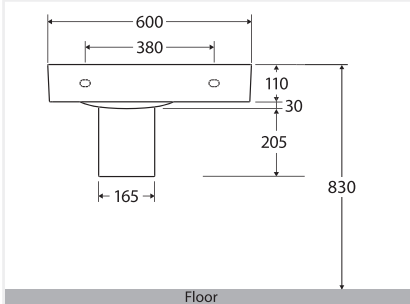

2. Hold the basin against the wall in the installing position according to the centre line and adjust to be flat and centre. Mark the position of the fixing holes on the wall.

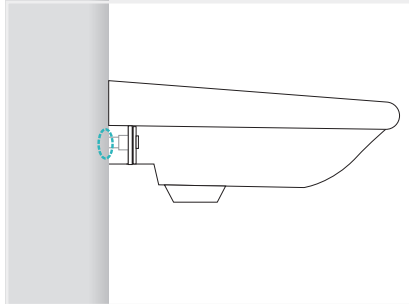

3. Remove the basin and drill two holes in masonry wall for using a 14mm masonry drill bit, to a depth of 75mm.

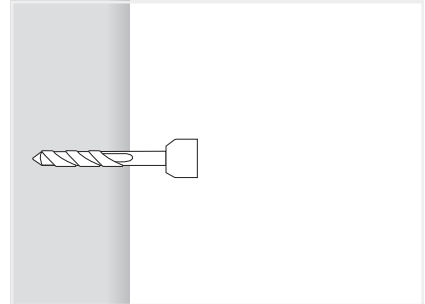

4. Push the wall plug into each hole.

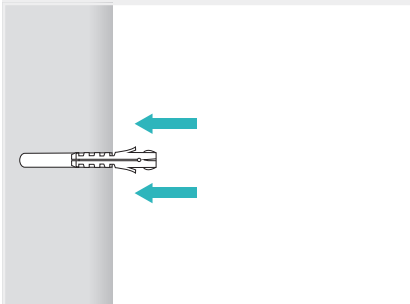

5. Screw a fixing bolt into each fixing plug an 8mm spanner until the spanner contacts the wall.

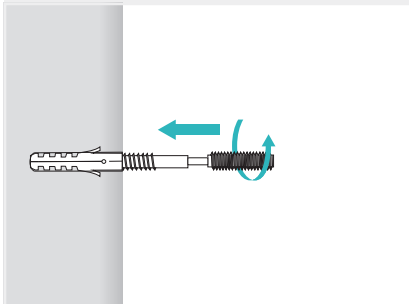

6. Place the basin in position against the wall, locating the fixing bolts through the holes in the rear of the basin. Push a plastic washer, followed by a metal washer, onto each fixing bolt.

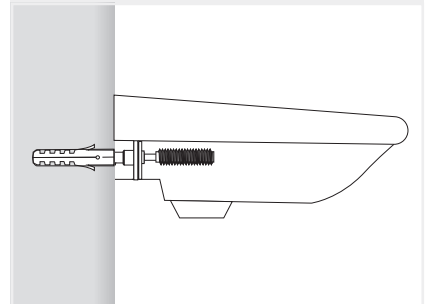

7. Screw a metal nut onto each fixing bolt to secure the basin.

Caution: Do not over tighten the bolts as this may damage the ceramic basin.

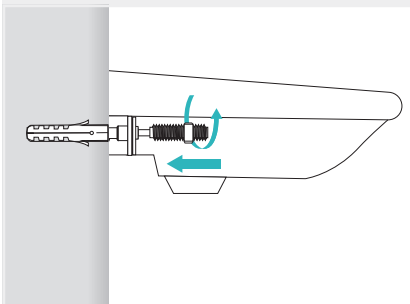

8. Install the tapware and the waste plug according to the installation instructions for the fittings. Connect the water supply pipe and the drainage pipe.

Note: Connect the hot water and cold water pipes according to the tapware markings.

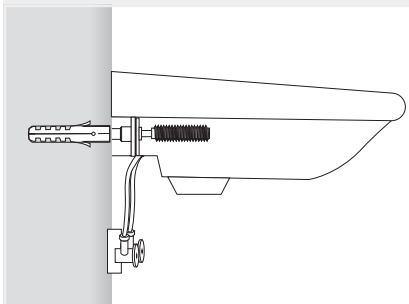

All installations should be carried out by a qualified tradesman in compliance with the National Plumbing & Drainage Code and any State or Local Authority Regulations, in accordance with AS/NZS 3500 series of standards and AS/NZA 6400. All measurements are in millimetres and are subject to change without notice. For ceramic products, please allow +/- 10 mm tolerance for manufacturing variance. Please refer to fienza.com.au for the latest product specification.

Shroud Installation

Parts

1. White plastic mounting brackets
2. 75mm hanging screws
3. 60mm fixing screws
4. Wall plugs
5. Plastic spacers
6. Cover caps



1. Put the shroud underneath the basin and align with the centre line. Carefully fit the shroud to the bottom of the basin. Mark screw holes on the wall in line with the shroud fixing holes on each side of the shroud. Remove the shroud and drill two holes into the wall for the 75mm long wall hanging screws.

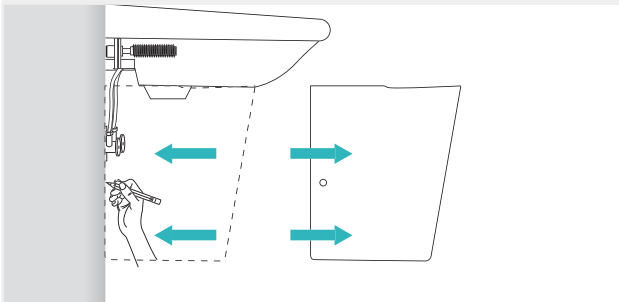

2. Push the wall plugs into the drilled holes. Place the white plastic mounting bracket up against the wall aligning with the screw holes and install Mounting Brackets onto the wall using the hanging screws and metal washers. Make sure the Mounting Brackets are straight

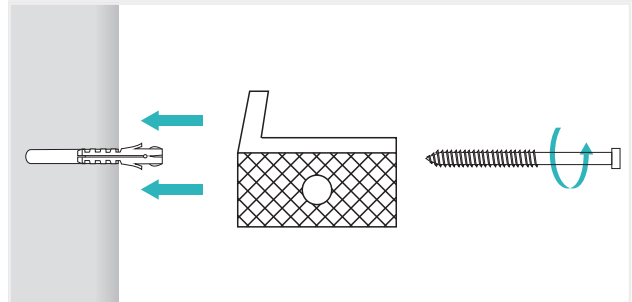

3. Put the shroud up against the wall and fit it well underneath the basin. Aligning the shroud fixing holes with the plastic mounting brackets. Put the 60mm counter sunk screws through the plastic spacers and install the screws through the shroud fixing holes into the plastic mounting bracket holes. Fasten the cover caps over the plastic spacers.

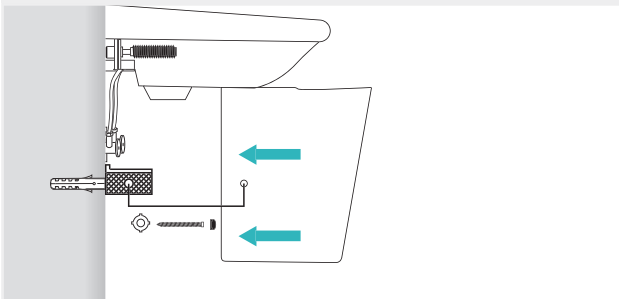

4. Use a layer of silicone around the edges of the basin and shroud where it meets the wall surface

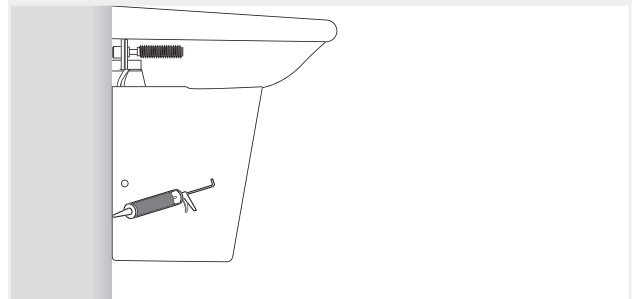

All installations should be carried out by a qualified tradesman in compliance with the National Plumbing & Drainage Code and any State or Local Authority Regulations, in accordance with AS/NZS 3500 series of standards and AS/NZA 6400. All measurements are in millimetres and are subject to change without notice. For ceramic products, please allow +/- 10 mm tolerance for manufacturing variance. Please refer to fienza.com.au for the latest product specification.

Warranties

Residential Warranty Periods

Applies to domestic uses and applications of Fienza® products, such as private dwellings and retirement villages.

Commercial Warranty Periods

Applies to commercial uses and applications of Fienza® products, including, but not limited to: commercial food premises such as restaurants; commercial accommodation such as hotels; hospitals and healthcare facilities; public amenities; and industrial, laboratory and manufacturing facilities.

Product Component	Residential	Commercial
Vitreous China	5 years replacement parts or product, 1 year labour	5 years replacement parts or product, 1 year labour
Accessories & Spare Parts	1 year replacement parts or product	1 year replacement parts or product

Australian Consumer Law

Our goods include guarantees that cannot be excluded under the Australian Consumer Law. You are entitled to a replacement or refund for a major failure and compensation for any other reasonably foreseeable loss or damage. You are also entitled to have the goods repaired or replaced if the goods fail to be of acceptable quality and the failure does not amount to a major failure.

Fienza Pty Ltd reserves the right to make changes in product characteristics, packaging or availability at any time without notice. Please visit fienza.com.au for the latest information.

Warranty Conditions

- Installation has been carried out by a licensed tradesperson in accordance with all applicable Building, Plumbing and Electrical codes, and Federal, State, or Local Government Regulations in accordance with AS/NZS 3500 Plumbing & Drainage, AS/NZS 6400 Water Efficient Products, and AS/NZS 3000 Electrical standards for any installations to which these standards apply.
- All maintenance and adjustments to the product after the installation have been carried out by a licensed tradesperson.
- All care and cleaning instructions have been adhered to as prescribed.
- All goods of substandard quality manufacture (excluding imperfections permitted within AS1976 - Vitreous China used in Sanitary Applications) will be credited or replaced by Fienza when advised within the warranty period, subject to prior inspection and agreement.
- Proof of purchase is required for warranty claims.

Warranty Limitations

To the extent permitted under the Trade Practices Act and other relevant legislation, Fienza's liability is limited to:

- The cost of replacing the goods, or
- The cost of obtaining equivalent goods, or
- The cost of having the goods repaired.
- Fienza is not responsible for any lack of operation or performance of goods (or any loss or damage) where goods are used or adapted for use with other goods not supplied by Fienza.
- It is the responsibility of the customer and installer before installation to ensure that all components are correct and free of obvious visible faults.
- Fienza is not responsible for the labour and rectification costs incurred in the above circumstance.

Conditions for On-Site Warranty Service Calls

Fienza will charge a service fee for each visit to an installation by its technician where it is determined that the fault is due to poorly executed or unlicensed installation work or where the product is not a genuine Fienza product or where the product is outside the warranty period. This may be paid in advance by credit card over the phone to a Fienza technician attending the site and will be refunded if the Fienza product is found to be at fault.

For warranty support, please contact Fienza

15 Walter Cres, Lawnton QLD 4501 PO Box 5381, Brendale QLD 4500
P 07 3490 6700 **F** 07 3490 6719 **E** help@fienza.com.au ABN 76 136 411 311



All installations should be carried out by a qualified tradesman in compliance with the National Plumbing & Drainage Code and any State or Local Authority Regulations, in accordance with AS/NZS 3500 series of standards and AS/NZA 6400. All measurements are in millimetres and are subject to change without notice. For ceramic products, please allow +/- 10 mm tolerance for manufacturing variance. Please refer to fienza.com.au for the latest product specification.