

Nero

WALL BASIN SET

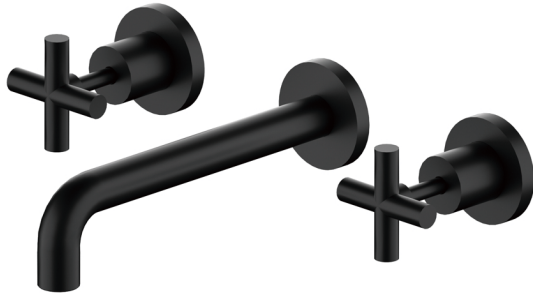

SPECIFICATION

PRODUCT CODE	YSW2016-07A
WELS RATING	5 STAR 5L/MIN
WATERMARK LICENSE	WM-060073
TEMPERATURE RATING	MIN 1°C-MAX 75°C
PRESSURE RATING	MIN 150KPa-MAX 500KPa

FINISH

■ NR201607aMB matt black

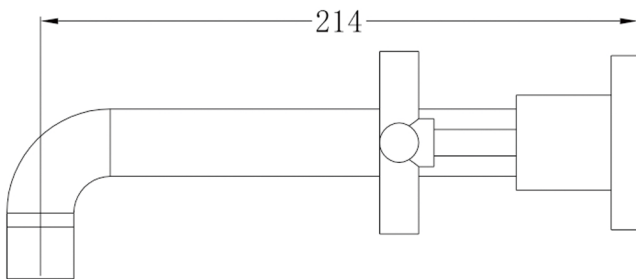
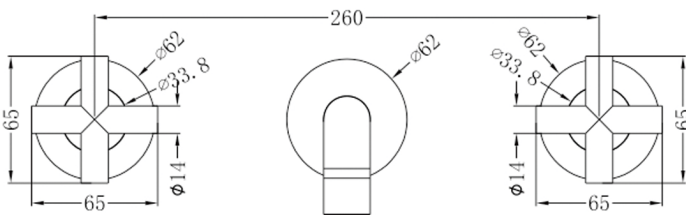

MAINTENANCE AND CARE

All surfaces should be cleaned with mild liquid detergent or soap and water.

Do not use cream cleaners or citrus based cleaning products, as they are abrasive.

Use of unsuitable cleaning agents may damage the surface. Any damage caused in this way will not be covered by warranty.

PACKAGING INCLUDES

- 2x hand wheel
- 1x spout
- 1x plate
- 1x wrench
- 1x installation kit

Dimensions are nominal measurements only.



Versions: 2019.12

www.nerotapware.com.au

1

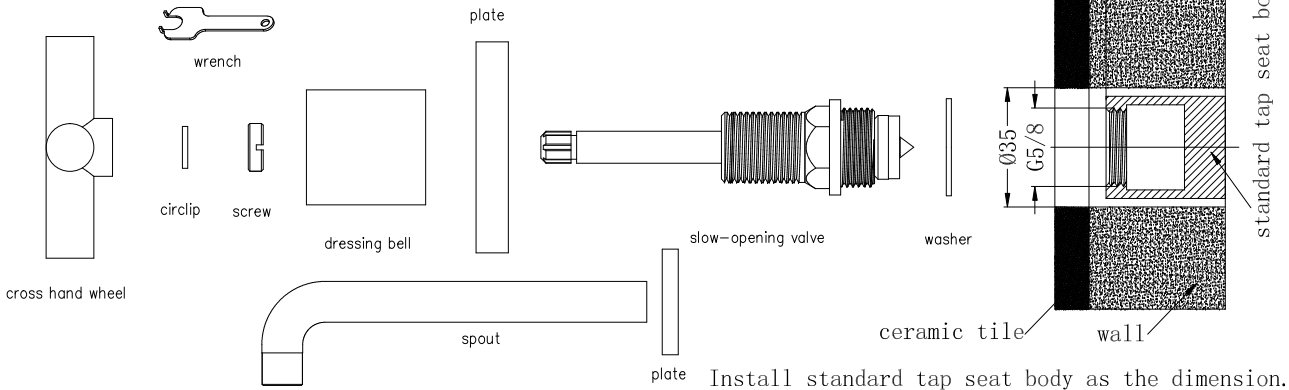

2

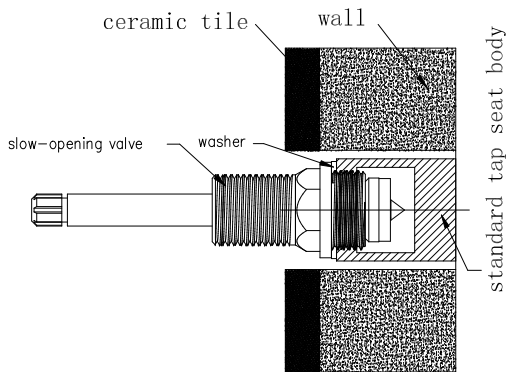

1. Put on the washer on the slow-opening valve.
2. Screw the slow-opening valve onto the body tightly.

3

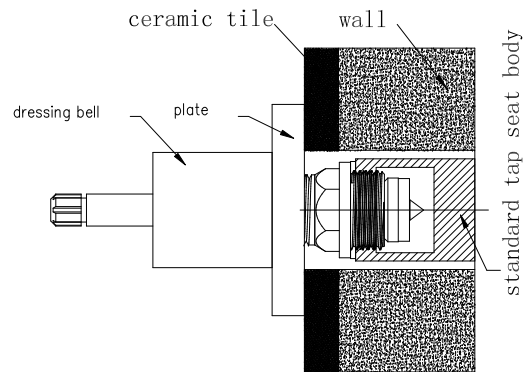

1. Put plate onto slow-opening valve.
2. Screw dressing bell tightly on the slow-opening valve.

4

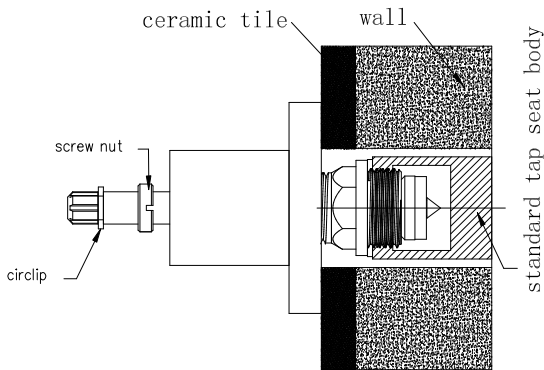

1. Put screw onto the stick of slow-opening valve.
2. Put circlip onto gap of slow-opening valve.

5

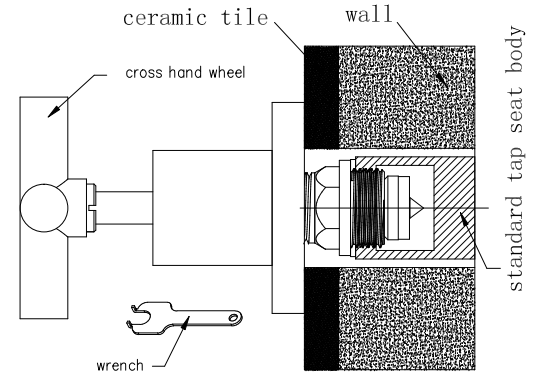

1. Put cross hand wheel onto stick of slow-opening valve, then adjust the rotation angle of hand wheel.
2. Use wrench to make screw into cross hand wheel, then tighten it up.

6

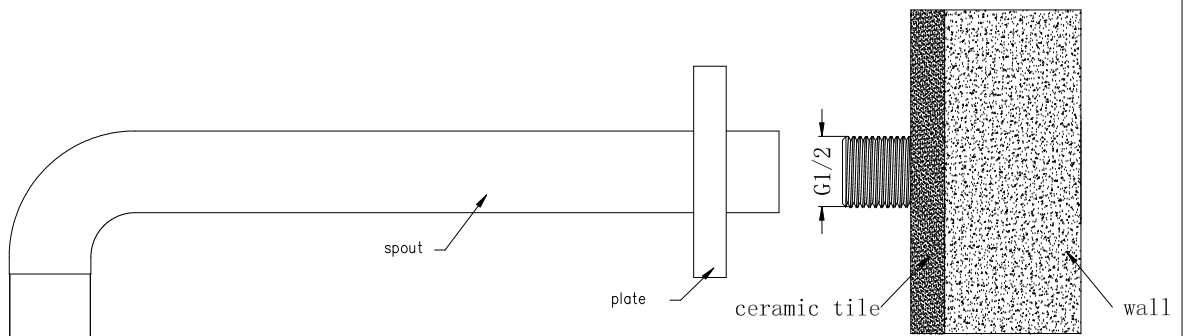

1. Put plate into spout.
2. Put spout onto the outlet, then put plate onto the ceramic tile.