

60cm Pyrolytic Multifunction Oven

BUILT-IN OVEN

PRODUCT CODE: **EO60MPYX**



eurocooking



FEATURES:

- + 10 multi-functions
- + Energy saving function
- + Self-cleaning – Pyrolytic cleaning function
- + Special pyrolysis enamel coating
- + Cool safety door (four glass, two glazed)
- + Automatic door lock during pyro function
- + Child lock safety
- + Full programmable timer digital control
- + Removable oven door
- + Contained cooling cavity
- + Stylish Black Design

3
YEARS

Warranty

10 MULTI-FUNCTIONS:



PYROLYTIC CLEANING FUNCTION

The pyrolytic self-cleaning function takes the hassle out of cleaning your oven. This also means you don't need to use nasty chemicals in your oven. At the touch of a button, your oven will heat up to 475° and begin to turn food scraps and oil into ash. This can be easily wiped away with a warm damp cloth, saving you the time and the hard work of cleaning.



CONVENTIONAL

This method of cooking provides traditional cooking with heat from the top and lower elements. Particularly suitable for traditional roasting and baking on the centre shelf only.



DOUBLE GRILL

Grill or toast enough of those favourite after school snacks to feed an army with the double grill function.



DOUBLE GRILL + FAN

This combination is exceptional for cooking meats such as poultry, game and roasts, making them crispy on the outside and tender in the middle.



OVEN LIGHT

The oven light will automatically turn on once any function is selected, helps to monitor the progress of your cooking.



FAN FORCED COOKING

For the ultimate roast or perfect batch of pastries. The element surrounding the fan delivers even heat for even cooking results, approx. 160°C - 180°C is recommended.



THERMOWAVE FAN ASSISTED

This is the position where the heat is coming from the lower and upper heating elements and the heat is circulated into the oven by the fan motor and blades.



BOTTOM ELEMENT

Great for pizza cooking, the bottom element creates the perfect cooking function for base cooked food



DEFROST

In defrost mode, no heating elements are used. Only the fan is activated to circulate air inside the oven for defrosting.



FULL GRILL

This function is perfect for fish, chicken Fillets or meat Cutlets.

SPECIFICATIONS:

Electrical Requirements	This oven can be connected to a 15 AMP wiring connection. For more information please refer to a qualified electrician.
Power Consumption	230-240v / 50Hz / 3200W
Oven Volume Capacity	80 litres (gross) - 70 litres (net)
Weight	44.0kg (gross) - 40.0kg (net)

PRODUCT DIMENSIONS:

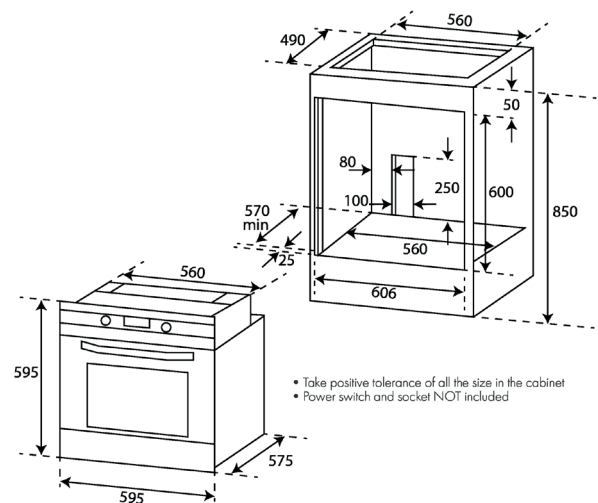

CLEANING AND MAINTENANCE

Easy clean AAA grade enamel interior.

Clean stainless steel using only recommended stainless steel cleaning products. No abrasives, corrosive detergents, bleaches or acids not required for cleaning the oven.