

# INSTALLATION, OPERATION AND MAINTENANCE INSTRUCTIONS



**RBA4150-103** Classic Backrest to AS1428.1



Model	RBA4150-103
Date	08/04/20
Doc#	ii/rba4150-103/0420

Supersedes all previous

**SYDNEY | MELBOURNE | BRISBANE | PERTH | AUCKLAND**

**Australia** 1300 788 778 [www.rba.com.au](http://www.rba.com.au) | **New Zealand** 0800 722 111 [www.rbagroup.co.nz](http://www.rbagroup.co.nz)

## Contents:

- 1x** Backrest cushion (Polyurethane)
- 4x** Backrest bolts
- 4x** Washers
- 1x** Satin Stainless steel frame
- 20x** Wall fixings screws & plugs

## Installation:

RBA Backrests meet the requirements of AS1428.1-2009 (Amdt 1-2010) when installed correctly.

- 1.** Secure the backrest cushion to the stainless steel frame using the bolts provided.
- 2.** To comply with AS1428.1, position the Backrest assembly against the wall so that the bottom of the cushion is 120-150mm above the seat of the Accessible WC. It should be located centrally above the WC.
- 3.** Mark the fixing locations accordingly.
- 4.** Mount the backrest assembly to the wall.
- 5.** Slide covers over mounting flanges to conceal fixings.

## Note for Designers & Installers:

The RBA4150-103 Classic Backrest has been designed to meet the requirements of AS1428.1-2009 (Incl Amdt 1 - 2010), when installed at the appropriate height and in conjunction with the leading brands of Accessible WC's and suites. It is not site adjustable. If you are uncertain about the suitability of the RBA4150-103 for your project, please consult RBA Group. Alternatively the RBA4150-101 is site adjustable.

**Warning:** Backrests are no stronger than the anchors or walls to which they are attached, and therefore, must be firmly secured in order to support the loads for which they are intended.

## Mounting Heights:

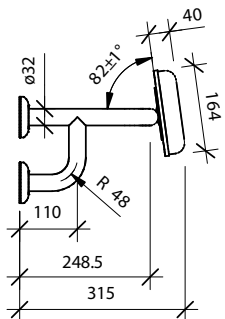
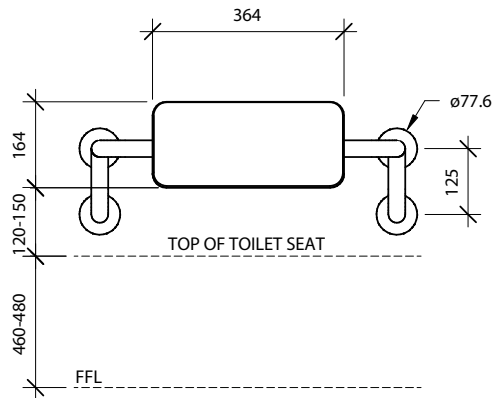
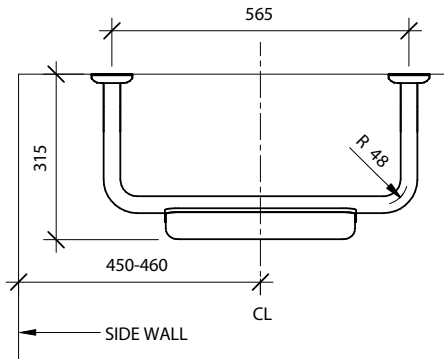

# INSTALLATION, OPERATION AND MAINTENANCE INSTRUCTIONS

**Note:** This product should be installed by suitably qualified persons in a fit for purpose application, to suitable materials and using suitable fixings and comply with any relevant codes. It should be inspected periodically for signs of wear and tear that may affect performance or safety.

Dimensions are subject to manufacturer's tolerance of +/-10mm. Rough-in should be completed with each fixture.

**Important:** Installation Instructions are subject to change without notice.

Please visit [www.rba.com.au](http://www.rba.com.au) for latest revision.

