

# CLARK® Flushline 8500 Laundry Tub

## INSTALLATION INSTRUCTION FOR OVERMOUNT SINK

1. Inspect sink for damage and dimensional compatibility. Do not attempt to install a damaged sink.
2. Using the cut-out template mark the exact location of the required cut-out in the benchtop and draw a pencil line against the edge of the template.
3. Ensure that the tap location is suitable. Ensure that the supplied cut-out gives the desired fit.
4. Before commencing cutting, double check the marked cut-out dimensions. Cut out the bench top carefully following the inside edge of the marked line. An exact cut is required to obtain the best fit.
5. For normal thickness bench tops, the attached fixing clips should be suitable. Lightly hammer the fixing clips onto the clip brackets along the product rim. (If the thickness of the bench top exceeds the range of the fixing clips then extension clips can be purchased and mounted onto the clip brackets. See Figure B)
6. Position the sink in the cut out hole and align properly. The fixing clips can be bent out of the way to assist installation (see Figure C).
7. Remove the sink and if required install the waste assemblies and the tap. It is suggested that silicone sealant be applied between the waste grate and the sink outlet hole.
8. Apply a continuous bead of silicone sealant along the edge of the sink and quickly place into position.
9. Bend the fixing clips straight so that the legs clear the hinge area. Tighten the clips evenly using a low torque setting (see Figure D). Note: over tightening the clip may strip the thread.
10. Plumb up the tap and waste fittings.

**NOTE:** For thin bench tops special clips (A0167) are available.

GWA Bathrooms & Kitchens bears no responsibility for faulty installation and the effects thereof.

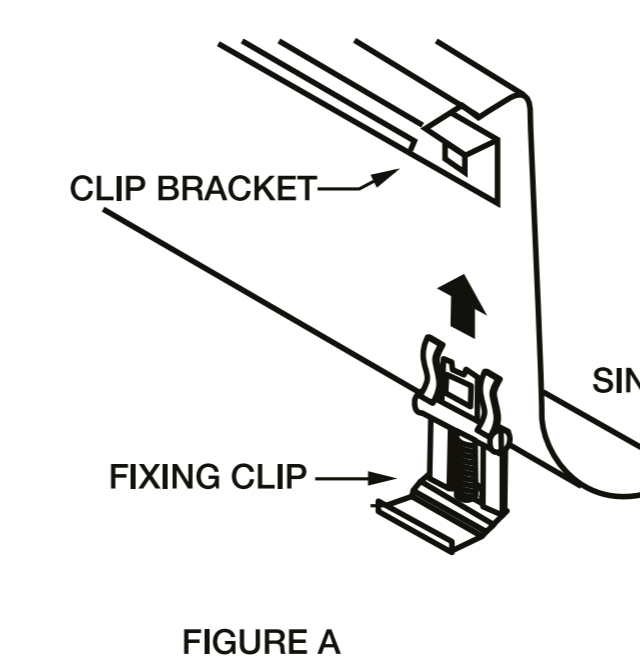

FIGURE A

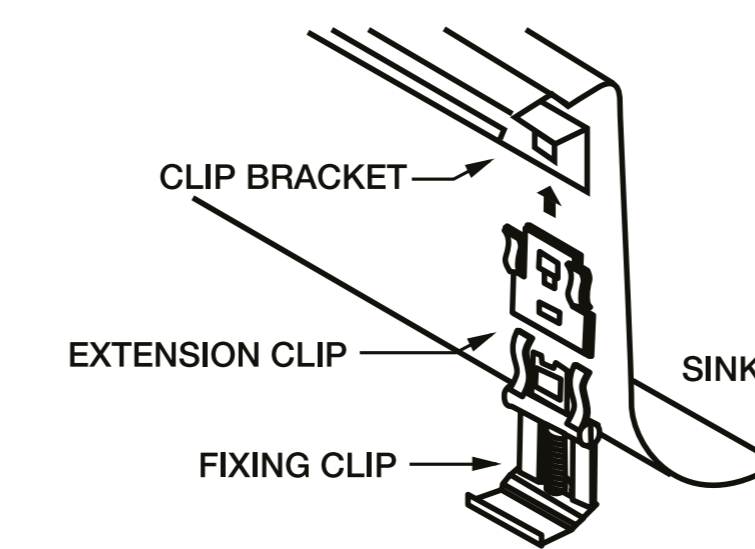

FIGURE B

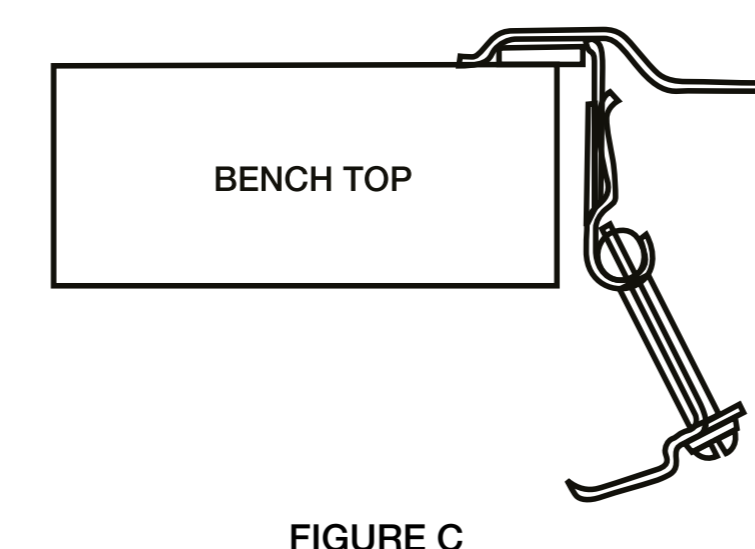

FIGURE C

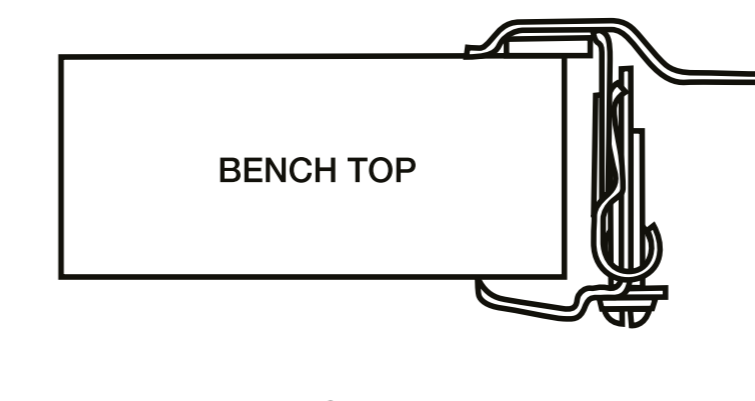

FIGURE D

R50

456 BENCH CUTOUT

616 BENCH CUTOUT

Issue No: 1  
Date of Issue: 01.10.2015