

PLUMBERS INSTALLATION INSTRUCTIONS

Important Information

- * Not suitable for gravity feed systems.
- * Swivel basin outlet is fitted with a 5 L/min flow regulated aerator insert.
This low flow rate may not be suitable for connection to some Instantaneous Gas Water Heaters, some Tempering Valves, some Solar Water Heaters & some Thermostatic Mixing Valves.
Check with the manufacturers of these products.
Note: An 8 L/min aerator insert kit (Part No.20744), is available if required.
- * Isolating stop taps are recommended to be fitted to the inlet connections. (Part No: 842018C- Mini cistern 1/4T)
- * All pipework must be thoroughly flushed prior to installation, as foreign materials may block the flow regulating device and reduce the flow of water.
Note: Aerator insert housing must be retightened to prevent removal by hand.

Installation

- 1) Measure centre distance between tap body holes in deck, cut breech piece (18) to required length. (As a guide see cutting template below)
- 2) Install basin outlet (22) with seal (21). Fit washer (20) and backnut (19) and tighten.
- 3) Fit compression nuts (17) and olives (16) to each end of breech piece (18), connect to tap bodies (15) and tighten compression nuts (17) slightly.
- 4) Fit one locknut (13) and one washer (14) to each tap body (15). Install assembly into deck ensuring 'O' rings on breech piece (18) are not damaged as they enter tail of basin outlet (22). Fit remaining washer (14) and locknut (13), adjust locknuts (13) so that the tap bodies (15) protrude 5mm above the deck and tighten.
- 5) Tighten compression nuts (17) on the breech piece (18).
- 6) To install ceramic disc cartridges (11), first identify cartridge spindle rotation by seal (12) colour.
Hot Tap: use normal rotation cartridge (red seal).
Cold Tap: use contra rotation cartridge (blue seal).

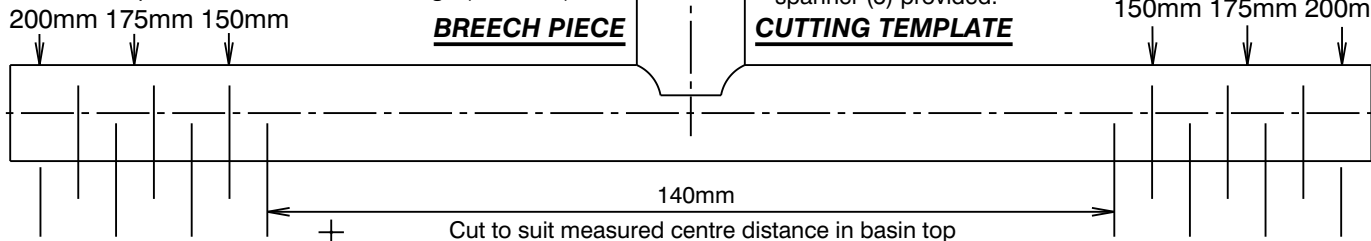

IMPORTANT	
Pressure & Temperature Requirements.	
•	Hot and cold water inlet pressures should be equal.
•	Static inlet pressure range : 150 - 1000 kPa New Regulation :- 500 kPa maximum static pressure at any outlet within a building. (Ref. AS/NZS 3500.1- 2003, Clause 3.3.4)
•	Maximum hot water temperature : 80°C.
Deck Requirements	
•	Centre distance between tap body holes :120- 210mm
•	Deck thickness : 25mm maximum
•	Tap body holes (in deck) : Ø34- 36mm
•	Tap outlet hole (in deck) : Ø22- 30mm

- 7) Remove locknut (9), cap (10) and fibre washer from cartridge (11). Screw cartridge (11) into tap body (15). Using a suitable spanner, tighten cartridge (11) until it comes to a firm stop. (DO NOT TIGHTEN CARTRIDGE USING SPINDLE). Fit fibre washer and then locknut (9) and tighten using a suitable spanner.
- 8) Ensure handle insert (2) is in position in handle (1). With cartridge spindles in the fully closed position, position handles (1) as shown in Fig.2 before pushing handle (1) fully onto spindle (8). For small adjustments to handle positions, cartridge (11) can be rotated **slightly** in an anti- clockwise direction until handles are aligned (Fig.2) before tightening locknut (9). Remove handles (1).
- 9) Fit coloured dress rings (7) accordingly (yellow replaces red for tempered water supply). Screw on flanges (6) to each locknut (9) and tighten securely by hand, taking care not to damage decorative finish.
- 10) Fit handle assembly as follows:-
 - i) Turn both spindles to the fully closed position.
 - ii) Place retaining nut (4) over spindle (8), with slot facing down.
 - iii) Fit retaining clip (3) into groove at bottom of spline in spindle (8).
 - iv) Ensure handle insert (2) is in position in handle (1). Fit handle (1) to spline of spindle, position handle as before then push firmly down until it bottoms internally.
 - v) Screw retaining nut (4) into handle and tighten with spanner (5) provided.

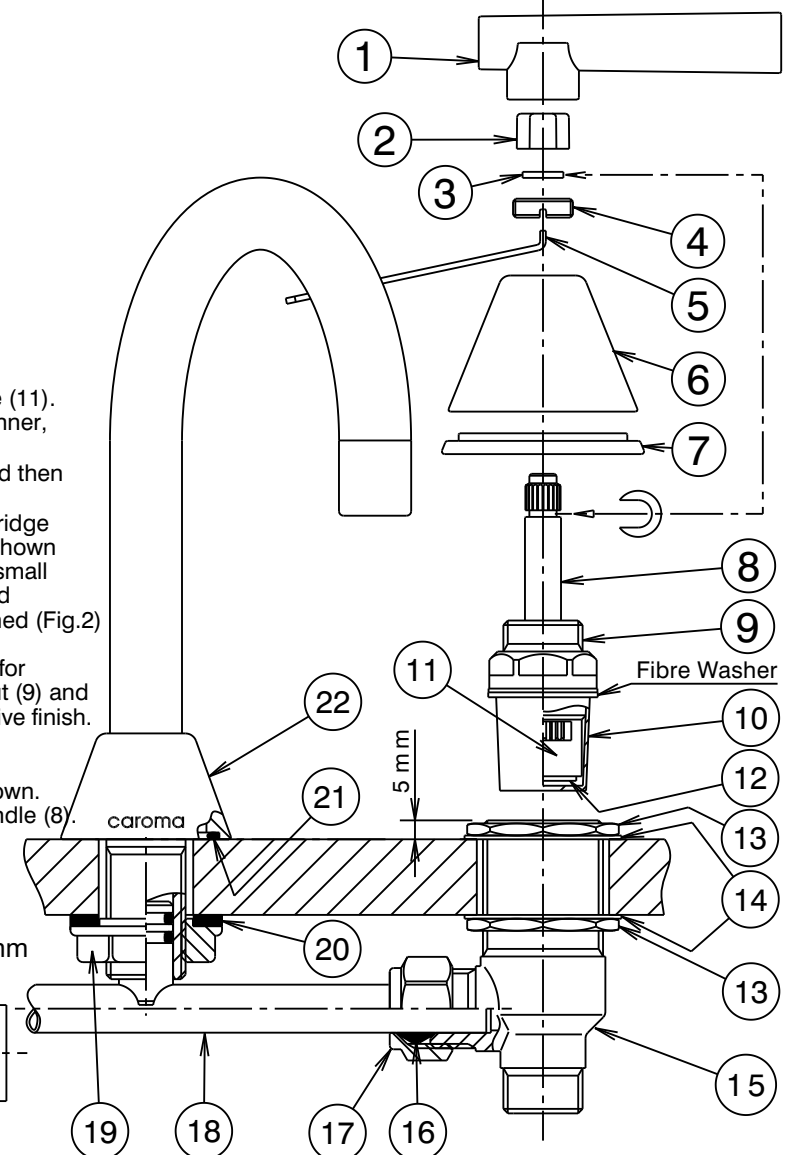
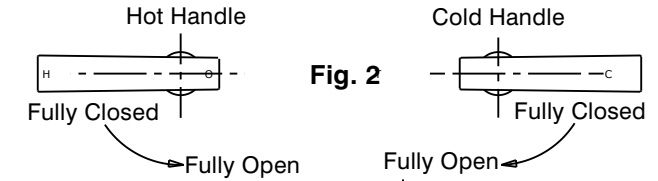

Fig. 1