

Shower Mixer Installation Guide

Technical Specifications:

Operating Pressure:

Min: 150kPa/1.5bar

Max: 500kPa/5bar*

Optimum: 150kPa/1.5bar - 500kPa/5bar

Operating Temperature:

Hot: Max 80°C*

Cold: Min 5°C

Inlet Connections:

All ½" BSP

** Regional specific regulations apply.
Please refer to your warranty statement
at www.methven.com*

Model No (AU):

03-9432M

03-8534M

Model No (NZ):

ELHPSCP

NEHPSCP

BLHPSCP

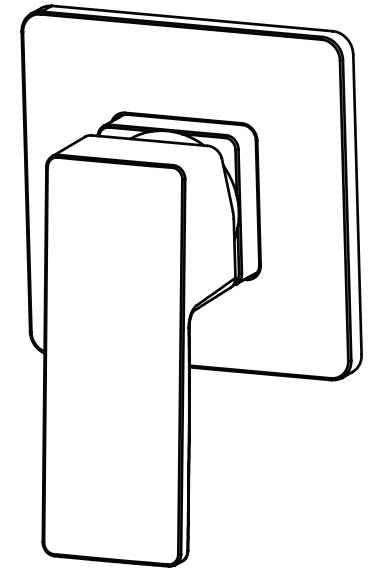

Care and Cleaning:

Never use abrasives or abrasive cleaning agents to clean this product. Clean regularly with contamination free warm soapy water and a damp soft cloth.

Methven warrants this product against manufacturing defects and that it is suitable for use under the general operating conditions specified in this instruction sheet. However, regional regulations apply and may affect your warranty. Please refer to www.methven.com or call customer service for full details.

New Zealand
0800 804 222

Australia
1300 638 483

UK
0800 195 1602

439833

ISSUE A

METHVEN
www.methven.com

IMPORTANT: Please read all of the instructions before installation.

General:

- Methven recommends this product is installed by a licensed plumber in compliance with all relevant regional regulations.
- Do not hydrostatic test the installation with this mixer installed. Damage to the ceramic cartridge may occur.
- All pipe work must be thoroughly flushed prior to the installation of the mixer.
- Do not remove the ceramic cartridge from the mixer when installing.
- After installation all connections must be checked for leaks.
- All outlets used primarily for personal hygiene shall deliver water at a safe temperature as per regional regulations.
- This mixer is not recommended for use in uncontrolled heating systems such as wet-backs or solar heating units unless a suitable tempering valve is fitted.
- It is the responsibility of the installer to ensure a waterproof seal is achieved between the product and mounting surface. If in doubt about the quality of the seal, remove the product and reinstall.

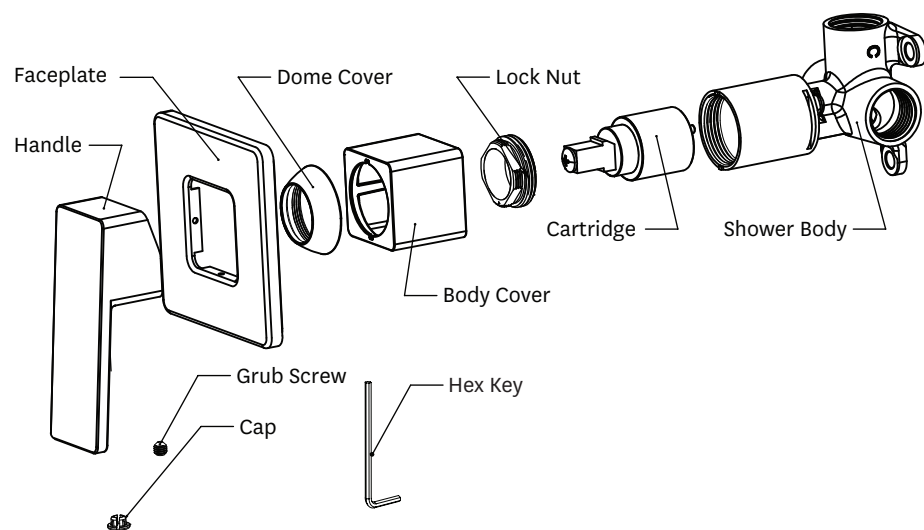

IMPORTANT: Before you begin, turn off the water supply.

Installation:

Step 1

- Leave plastic cover in place during the installation. Plastic cover shape may vary depending on product.
- Installation depth, **ID= 60 ± 10mm**. This is defined as the distance between the mounting surface and the finished wall surface.
- Secure the mixer body on to the supporting timber ensuring that it is oriented square and vertical.

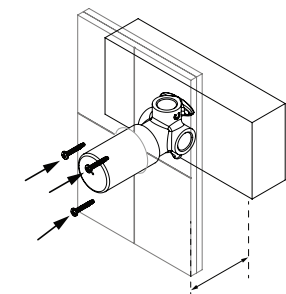

ID= 60 ± 10mm

Step 2

- Flush all pipe-work thoroughly prior to the next step.
- Connect mixer body to hot and cold supplies and outlet ensuring a good seal at each joint.
- Leak test installation prior to closing wall cavity.

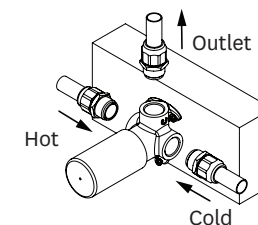

Step 3

- Wall lining should be cut or finished to observe the dimensions of the holes provided in the diagram on the right.

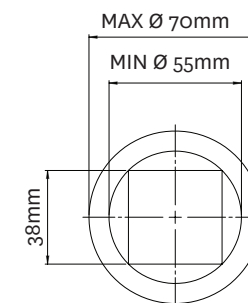

Step 4

- Remove plastic covers.
- Use silicone to seal around the body cover of the mixer to the finished wall surface.
- Wet the faceplate body seal.
- Slide plate onto mixer body and position with notch in plate towards the bottom.
- Push handle on to cartridge pin, tighten grub screw firmly with hex key provided and cap the grub screw hole with the chrome cover.

