



# PHOENIX

## SPECIFICATIONS

### VIVID SLIMLINE

### SHOWER/WALL MIXER

PRODUCT CODE: VS780 MB  
 FINISH: MATTE BLACK  
 WELS: N/A

#### INFORMATION:

MATERIAL: BRASS  
 TEMPERATURE RATING: MIN 1° - MAX 75°  
 PRESSURE RATING: MIN 150 kPa - MAX 500 kPa

#### CONSUMER UNIT:

SIZE: L 190MM x W 140MM x H 75MM  
 GROSS WEIGHT: 0.9 KG  
 BARCODE EAN-13: 9 320594 021 429



ALSO AVAILABLE IN:



FOR MORE INFORMATION VISIT [www.phoenixtapware.com.au](http://www.phoenixtapware.com.au)

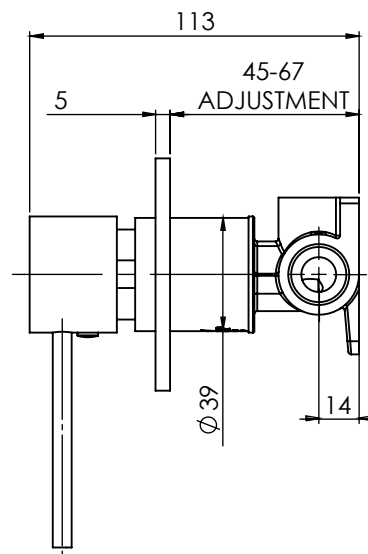
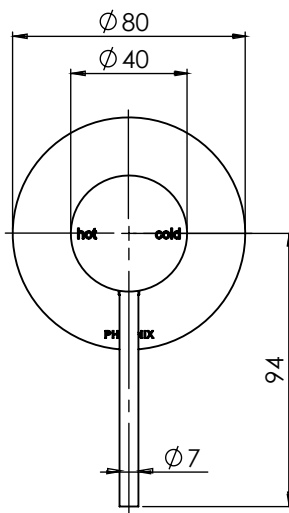

PLEASE [CLICK HERE](#) TO VIEW FULL WARRANTY

While we aim to ensure the specifications shown are correct at time of printing, Phoenix Tapware reserves the right to make modifications without prior notice. Always use the physical product measurements for mark-ups and roughing-in as the line drawing shown may differ from the actual product over time. All measurements are shown in millimetres.

[www.phoenixtapware.com.au](http://www.phoenixtapware.com.au)  
03 9780 4200



# PHOENIX

## SPECIFICATIONS

### VIVID SLIMLINE

### SHOWER/WALL MIXER

PRODUCT CODE:

VS780 MB

FINISH:

MATTE BLACK

WELS:

N/A



#### PARTS LIST

1. MIXER SLEEVE
2. MIXER BREACH
3. 35MM CARTRIDGE
4. O-RING 39X2.5MM
5. MIXER LOCKNUT
6. GRUB SCREW M5X5MM
7. SCREW CAP M5
8. BACK PLATE
9. MIXER HANDLE
10. PIN LEVER
11. O-RING 33X2MM

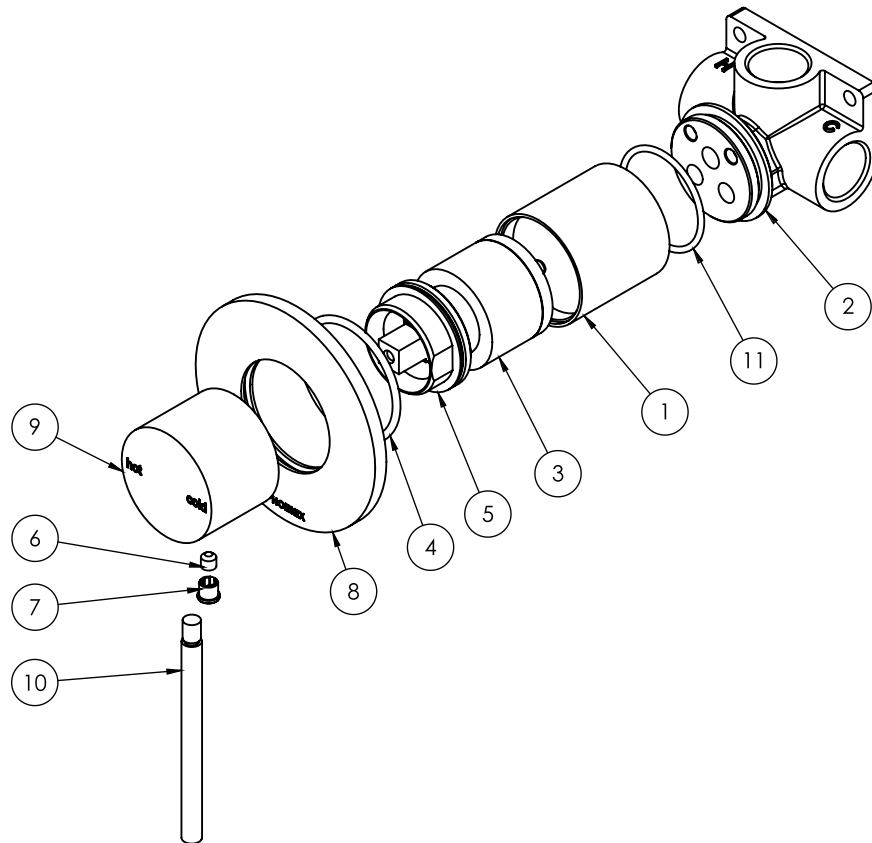

#### MAINTENANCE AND CARE:

- All surfaces should be cleaned with mild liquid detergent or soap and water.
- Do not use cream cleaners or citrus based cleaning products, as they are abrasive.
- Use of unsuitable cleaning agents may damage the surface. Any damage caused in this way will not be covered by warranty.

#### PACKAGING INCLUDES

- 1 x Shower/wall mixer
- 1 x Installation kit
- 1 x Installation instructions
- 1 x Warranty card

PLEASE [CLICK HERE](#) TO VIEW FULL WARRANTY

While we aim to ensure the specifications shown are correct at time of printing, Phoenix Tapware reserves the right to make modifications without prior notice. Always use the physical product measurements for mark-ups and roughing-in as the line drawing shown may differ from the actual product over time. All measurements are shown in millimetres.

[www.phoenixtapware.com.au](http://www.phoenixtapware.com.au)  
03 9780 4200