



PHOENIX

SPECIFICATIONS

RUSH

BASIN MIXER

PRODUCT CODE: RU770 MB
 FINISH: MATTE BLACK
 WELS: 6 STAR - 3.5 LT/MIN

INFORMATION:

TEMPERATURE RATING: MIN 1° - MAX 75°
 PRESSURE RATING: MIN 150 kPa - MAX 500 kPa



AVAILABLE IN:



CHROME MATTE BLACK BRUSHED NICKEL

FOR MORE INFORMATION VISIT www.phoenixtapware.com.au

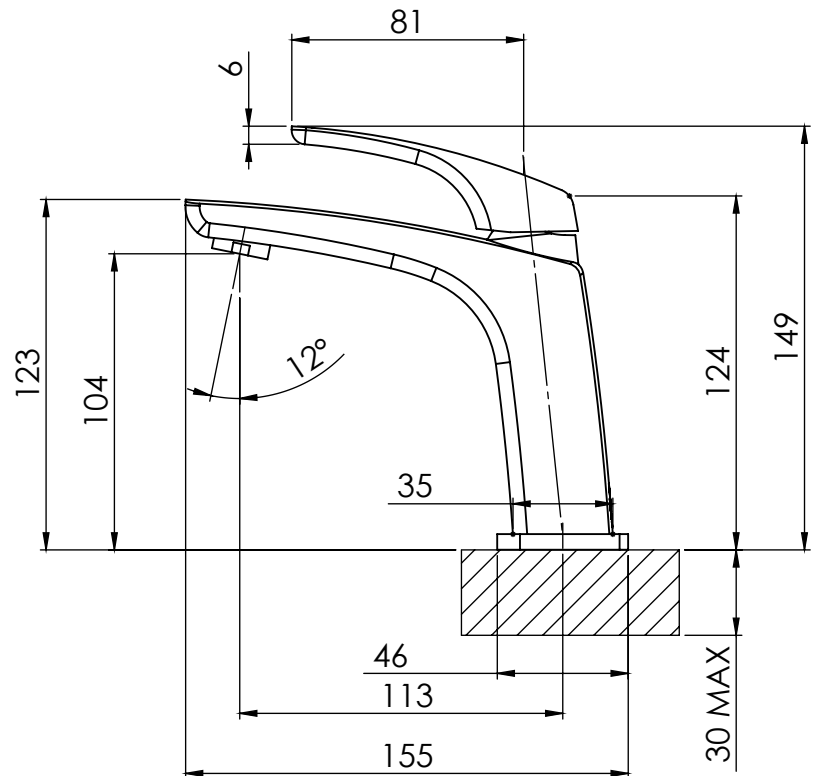
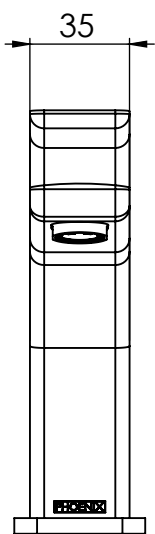

PLEASE [CLICK HERE TO VIEW FULL WARRANTY](#)

While we aim to ensure the specifications shown are correct at time of printing, Phoenix Tapware reserves the right to make modifications without prior notice. Always use the physical product measurements for mark-ups and roughing-in as the line drawing shown may differ from the actual product over time. All measurements are shown in millimetres.

www.phoenixtapware.com.au
03 9780 4200



PHOENIX

SPECIFICATIONS

RUSH

BASIN MIXER

PRODUCT CODE:

RU770 MB

FINISH:

MATTE BLACK

WELS:

6 STAR - 3.5 LT/MIN



PARTS LIST

1. MIXER BODY
2. 25MM CARTRIDGE
3. MIXER HANDLE
4. GRUB SCREW M4X5MM
5. MIXER LOCKNUT
6. O-RING 22X2.0MM
7. MIXER DOME
8. O-RING 16X1.5MM
9. AERATOR RETAINER
10. AERATOR
11. DRESS PLATE
12. SCREW
13. RUBBER WASHER
14. FLEXIBLE HOSE 450MM COLD
15. FLEXIBLE HOSE 450MM HOT
16. FIXING PLATE
17. RUBBER GASKET
18. M8 THREADED ROD
19. M8 NUT

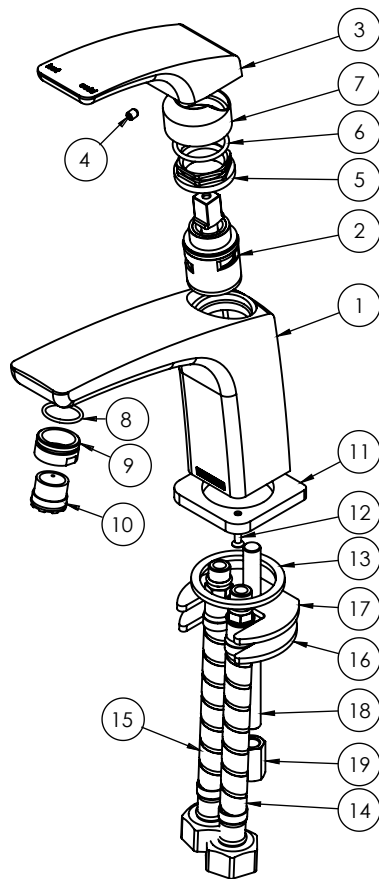

MAINTENANCE AND CARE:

- All surfaces should be cleaned with mild liquid detergent or soap and water.
- Do not use cream cleaners or citrus based cleaning products, as they are abrasive.
- Use of unsuitable cleaning agents may damage the surface. Any damage caused in this way will not be covered by warranty.

PACKAGING INCLUDES

- 1 x Basin mixer
- 1 x Installation kit
- 1 x 450mm braided flexible cold hose
- 1 x 450mm braided flexible hot hose
- 1 x Installation instructions
- 1 x Warranty card

PLEASE [CLICK HERE](#) TO VIEW FULL WARRANTY

While we aim to ensure the specifications shown are correct at time of printing, Phoenix Tapware reserves the right to make modifications without prior notice. Always use the physical product measurements for mark-ups and roughing-in as the line drawing shown may differ from the actual product over time. All measurements are shown in millimetres.

Designed and Registered in Australia by Phoenix Industries Pty. Ltd

V211117

www.phoenixtapware.com.au
03 9780 4200