



PHOENIX

SPECIFICATIONS

ARGO

SHOWER /WALL MIXER

PRODUCT CODE: AG780 CHR
 FINISH: CHROME
 WELS: N/A

INFORMATION:

TEMPERATURE RATING: MIN 1° - MAX 75°
 PRESSURE RATING: MIN 150 kPa - MAX 500 kPa



AVAILABLE IN:



CHROME

FOR MORE INFORMATION VISIT
www.phoenixtapware.com.au

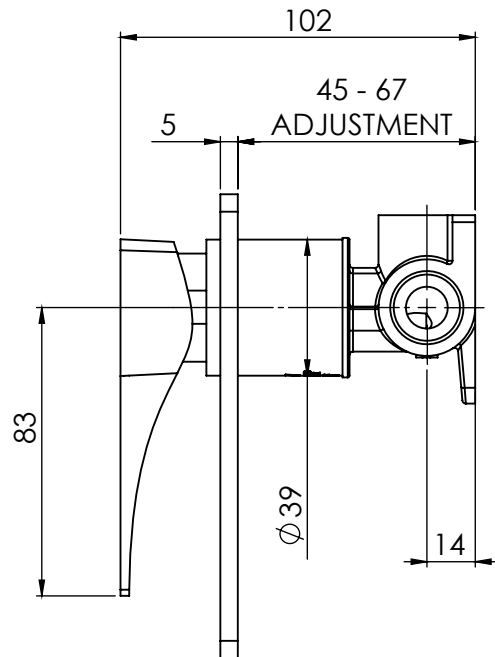
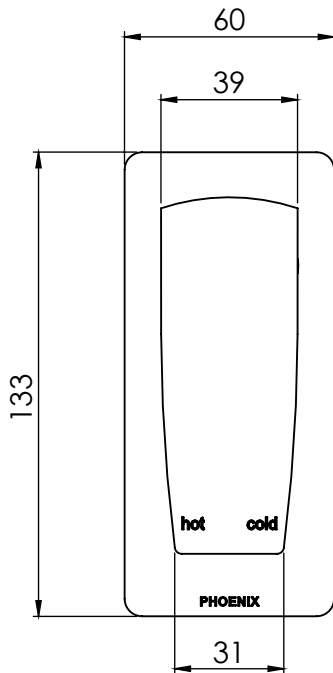

PLEASE [CLICK HERE TO VIEW FULL WARRANTY](#)

While we aim to ensure the specifications shown are correct at time of printing, Phoenix Tapware reserves the right to make modifications without prior notice. Always use the physical product measurements for mark-ups and roughing-in as the line drawing shown may differ from the actual product over time. All measurements are shown in millimetres.

ARGO is a Registered Trademark of Phoenix Industries Pty. Ltd.

V201216

www.phoenixtapware.com.au
03 9780 4200



PHOENIX

SPECIFICATIONS

ARGO

SHOWER /WALL MIXER

PRODUCT CODE:

AG780 CHR

FINISH:

CHROME

WELS:

N/A



PARTS LIST

1. WALL BREACH
2. MIXER SLEEVE
3. 35MM CARTRIDGE
4. O-RING 39X2.5MM
5. LOCKNUT DOME
6. GRUB SCREW M4X5MM
7. O-RING 33X2.0MM
8. MIXER HANDLE
9. BACKPLATE

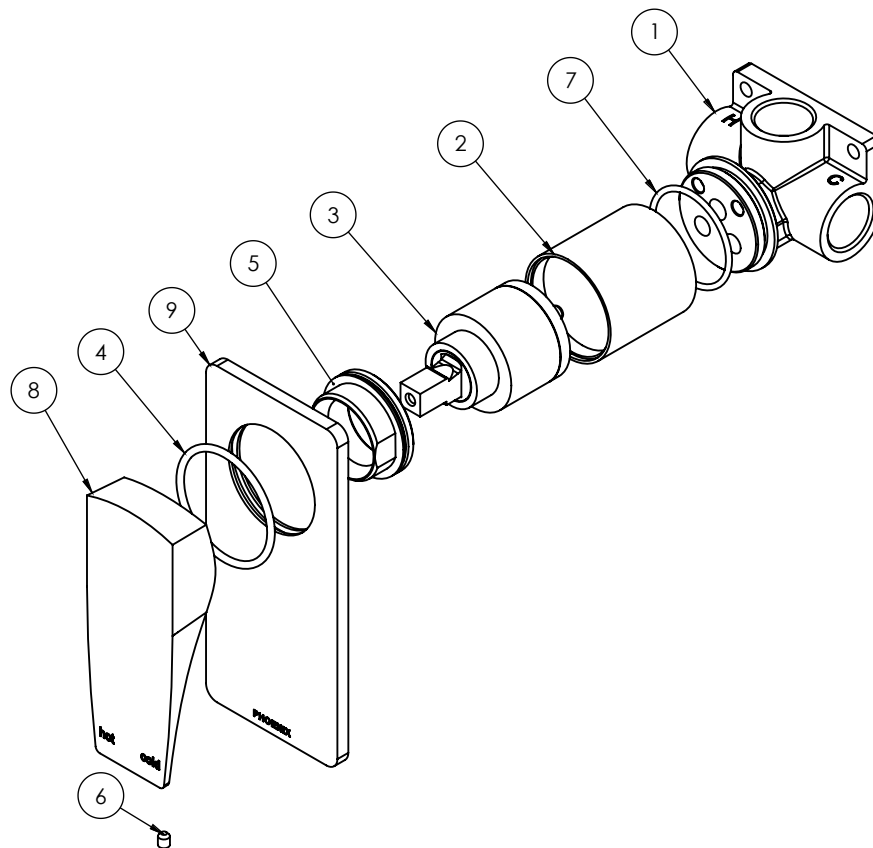

MAINTENANCE AND CARE:

- All surfaces should be cleaned with mild liquid detergent or soap and water.
- Do not use cream cleaners or citrus based cleaning products, as they are abrasive.
- Use of unsuitable cleaning agents may damage the surface. Any damage caused in this way will not be covered by warranty.

PACKAGING INCLUDES

- 1 x Shower/Wall Mixer
- 1 x Installation kit
- 1 x Installation instructions
- 1 x Warranty card

PLEASE [CLICK HERE](#) TO VIEW FULL WARRANTY

While we aim to ensure the specifications shown are correct at time of printing, Phoenix Tapware reserves the right to make modifications without prior notice. Always use the physical product measurements for mark-ups and roughing-in as the line drawing shown may differ from the actual product over time. All measurements are shown in millimetres.

ARGO is a Registered Trademark of Phoenix Industries Pty. Ltd.

V201216

www.phoenixtapware.com.au
03 9780 4200