



# PHOENIX

## SPECIFICATIONS

### VIVID SLIMLINE OVAL

### SHOWER / BATH DIVERTER MIXER

PRODUCT CODE: VV791 MB  
 FINISH: MATTE BLACK  
 WELS: N/A

#### INFORMATION:

TEMPERATURE RATING: MIN 1° - MAX 75°  
 PRESSURE RATING: MIN 150 kPa - MAX 500 kPa



AVAILABLE IN:



CHROME BRUSHED NICKEL MATTE BLACK

FOR MORE INFORMATION VISIT [www.phoenixtapware.com.au](http://www.phoenixtapware.com.au)

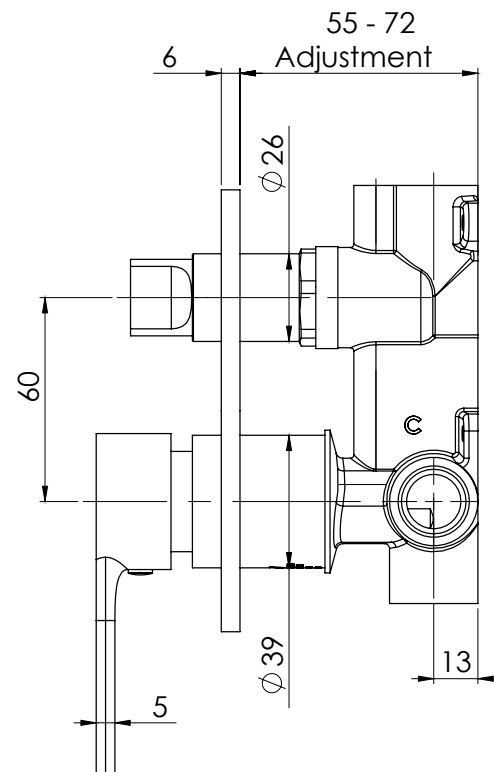
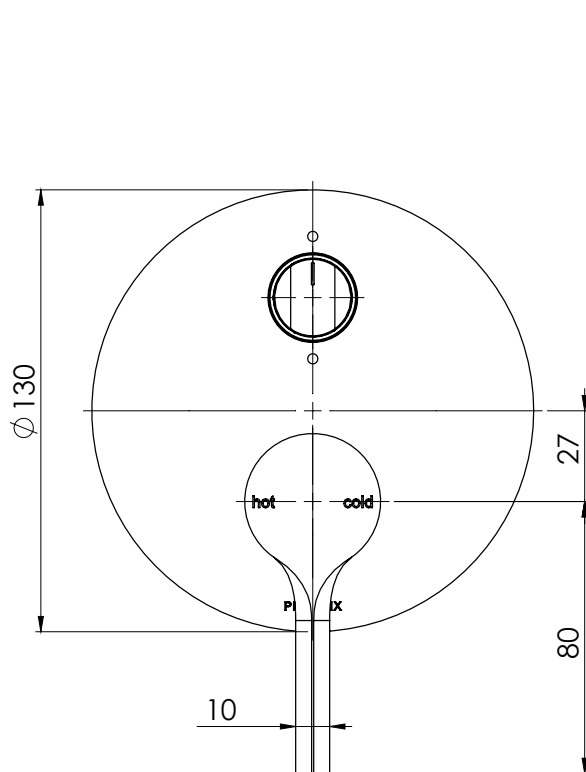

PLEASE [CLICK HERE TO VIEW FULL WARRANTY](#)

While we aim to ensure the specifications shown are correct at time of printing, Phoenix Tapware reserves the right to make modifications without prior notice. Always use the physical product measurements for mark-ups and roughing-in as the line drawing shown may differ from the actual product over time. All measurements are shown in millimetres. Some colours may vary across product types due to differing construction materials. Printed images are a representation only and the colour or finish may vary from the actual product.

[www.phoenixtapware.com.au](http://www.phoenixtapware.com.au)  
03 9780 4200



# PHOENIX

## SPECIFICATIONS

### VIVID SLIMLINE OVAL

### SHOWER / BATH DIVERter MIXER

PRODUCT CODE:

VV791 MB

FINISH:

MATTE BLACK

WELS:

N/A



#### PARTS LIST

1. DIVERter MIXER BODY
2. 35MM MIXING CARTRIDGE
3. DIVERter CARTRIDGE
4. DIVERter SLEEVE
5. ROTARY DIVERter BUTTON SQUARE
6. DIVERter SPINDLE ADAPTOR
7. COUNTERSUNK M4X1.4MM
8. DIVERter NYLON BEARING
9. GRUB SCREW M4X4
10. O-RING 33X2.0MM
11. MIXER SLEEVE
12. LOCKNUT DOME
13. MIXER HANDLE
14. DRESS PLATE
15. O-RING 26X2.5MM
16. O-RING 39X2.5MM
17. GRUB SCREW CAP

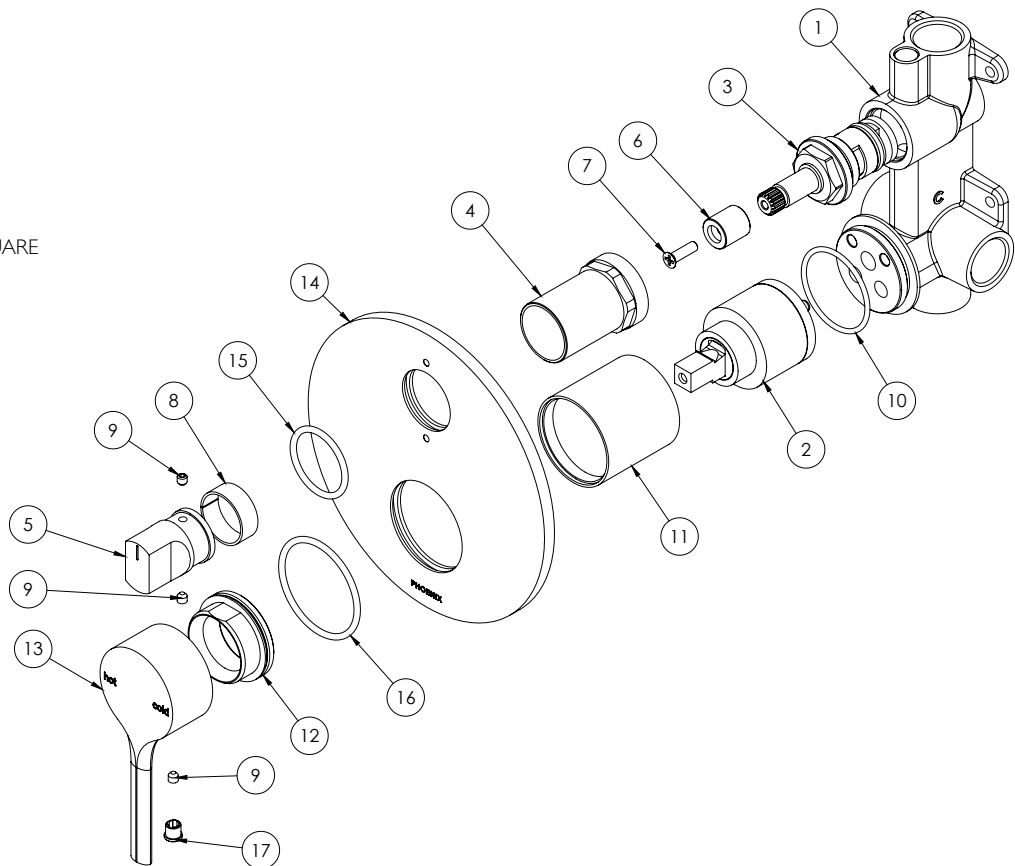

#### MAINTENANCE AND CARE:

- All surfaces should be cleaned with mild liquid detergent or soap and water.
- Do not use cream cleaners or citrus based cleaning products, as they are abrasive.
- Use of unsuitable cleaning agents may damage the surface. Any damage caused in this way will not be covered by warranty.

#### PACKAGING INCLUDES

- 1 x Shower/ bath diverter
- 1 x Installation kit
- 1 x Dress plate
- 1 x Mixer handle
- 1 x Installation instructions
- 1 x Warranty card

PLEASE [CLICK HERE](#) TO VIEW FULL WARRANTY

While we aim to ensure the specifications shown are correct at time of printing, Phoenix Tapware reserves the right to make modifications without prior notice. Always use the physical product measurements for mark-ups and roughing-in as the line drawing shown may differ from the actual product over time. All measurements are shown in millimetres. Some colours may vary across product types due to differing construction materials. Printed images are a representation only and the colour or finish may vary from the actual product.

[www.phoenixtapware.com.au](http://www.phoenixtapware.com.au)

03 9780 4200