



PHOENIX

SPECIFICATIONS

VIVID SLIMLINE OVAL

WALL BASIN MIXER SET 175MM

PRODUCT CODE:	VV785 MB
FINISH:	MATTE BLACK
WELS:	6 STAR - 4.0 LT/MIN
INFORMATION:	
TEMPERATURE RATING:	MIN 1° - MAX 75°
PRESSURE RATING:	MIN 150 kPa - MAX 500 kPa



AVAILABLE IN:



CHROME BRUSHED NICKEL MATTE BLACK

FOR MORE INFORMATION VISIT www.phoenixtapware.com.au

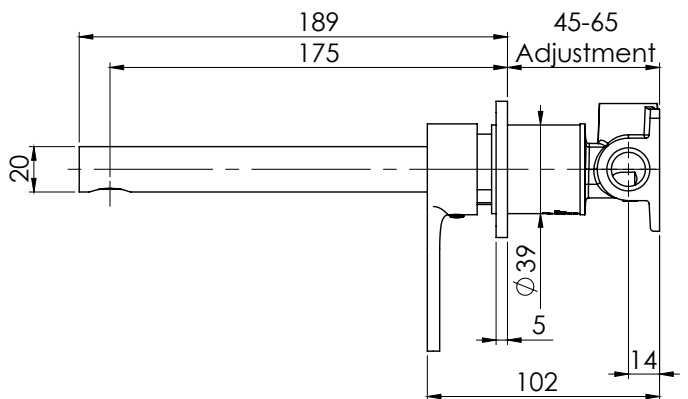
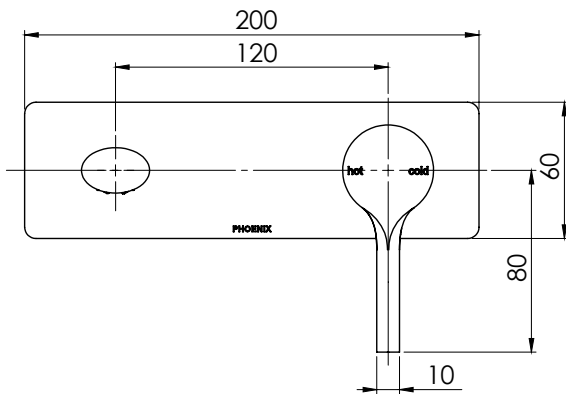

PLEASE [CLICK HERE](#) TO VIEW FULL WARRANTY

While we aim to ensure the specifications shown are correct at time of printing, Phoenix Tapware reserves the right to make modifications without prior notice. Always use the physical product measurements for mark-ups and roughing-in as the line drawing shown may differ from the actual product over time. All measurements are shown in millimetres. Some colours may vary across product types due to differing construction materials. Printed images are a representation only and the colour or finish may vary from the actual product.

www.phoenixtapware.com.au
03 9780 4200



PHOENIX

SPECIFICATIONS

VIVID SLIMLINE OVAL

WALL BASIN MIXER SET 175MM

PRODUCT CODE:

VV785 MB

FINISH:

MATTE BLACK

WELS:

6 STAR - 4.0 LT/MIN



PARTS LIST

1. WALL BREACH
2. WALL MIXER SLEEVE
3. LOCK NUT DOME
4. BACK PLATE
5. O-RING 39X3.5MM
6. AERATOR
7. GRUB SCREW M4X5
8. SCREW CAP
9. SPOUT ADAPTER
10. O-RING 11X2.0MM
11. 35MM CARTRIDGE
12. OVAL SPOUT
13. GRUB SCREW M5X5
14. MIXER HANDLE
15. O-RING 33X2.0MM

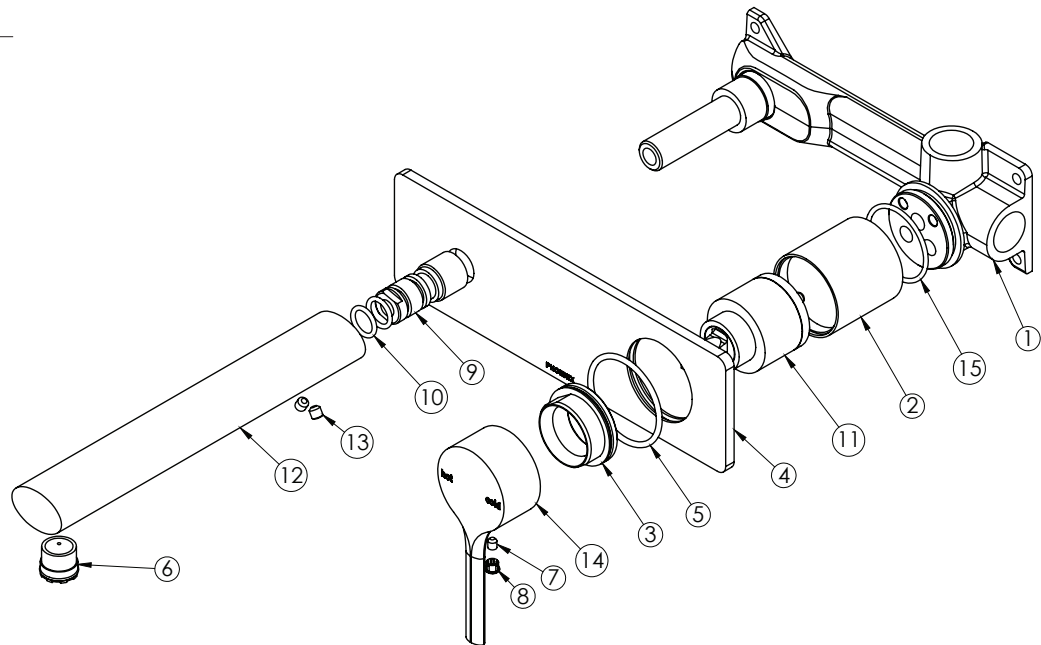

MAINTENANCE AND CARE:

- All surfaces should be cleaned with mild liquid detergent or soap and water.
- Do not use cream cleaners or citrus based cleaning products, as they are abrasive.
- Use of unsuitable cleaning agents may damage the surface. Any damage caused in this way will not be covered by warranty.

PACKAGING INCLUDES

- 1 x Wall basin mixer set 175mm
- 1 x Installation kit
- 1 x Installation instructions
- 1 x Warranty card

PLEASE [CLICK HERE TO VIEW FULL WARRANTY](#)

While we aim to ensure the specifications shown are correct at time of printing, Phoenix Tapware reserves the right to make modifications without prior notice. Always use the physical product measurements for mark-ups and roughing-in as the line drawing shown may differ from the actual product over time. All measurements are shown in millimetres. Some colours may vary across product types due to differing construction materials. Printed images are a representation only and the colour or finish may vary from the actual product.

www.phoenixtapware.com.au

03 9780 4200