



PHOENIX

SPECIFICATIONS

GLOSS

SINK MIXER 200MM SQUARELINE

PRODUCT CODE: GS731 CHR
 FINISH: CHROME
 WELS: 5 STAR - 6.0 LT/MIN

INFORMATION:

MATERIAL: BRASS (OR OTHER)
 TEMPERATURE RATING: MIN 1° - MAX 75°
 PRESSURE RATING: MIN 150 kPa - MAX 500 kPa

CONSUMER UNIT:

SIZE: L 360MM x W 290MM x H 75MM
 GROSS WEIGHT: 2.0 KG
 BARCODE EAN-13: 9 320594 018 191



AVAILABLE IN:



CHROME

FOR MORE INFORMATION VISIT
www.phoenixtapware.com.au

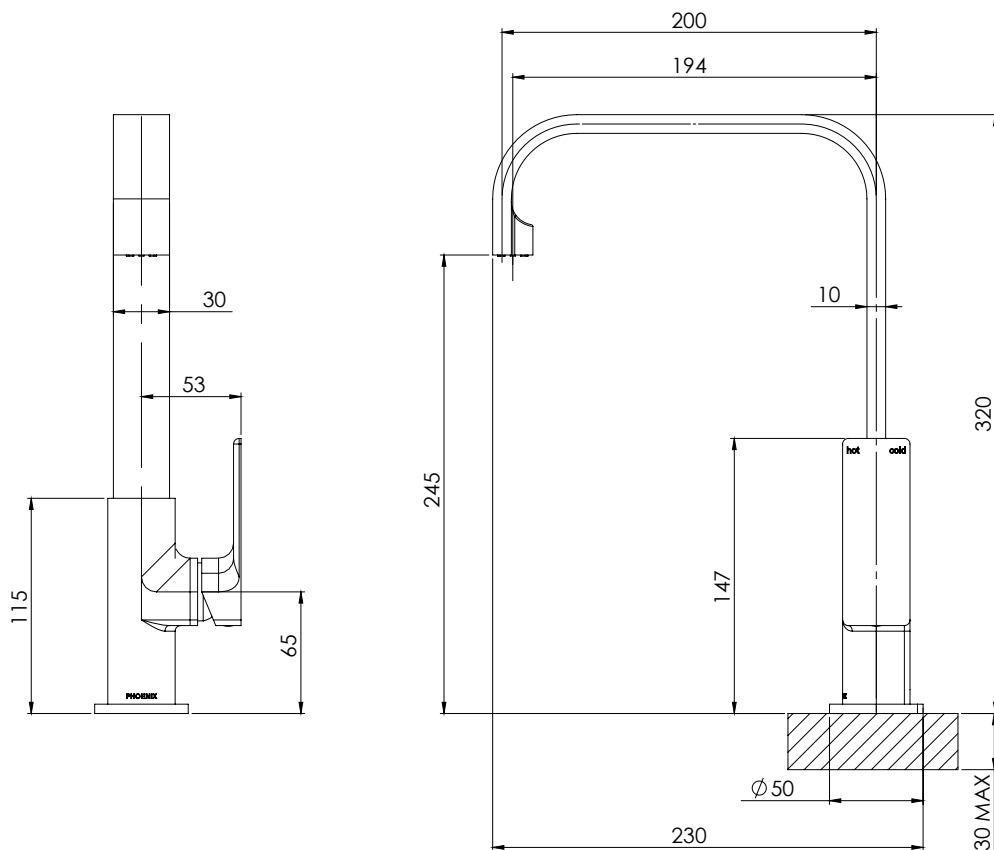

PLEASE [CLICK HERE TO VIEW FULL WARRANTY](#)

While we aim to ensure the specifications shown are correct at time of printing, Phoenix Tapware reserves the right to make modifications without prior notice. Always use the physical product measurements for mark-ups and roughing-in as the line drawing shown may differ from the actual product over time. All measurements are shown in millimetres.

www.phoenixtapware.com.au
03 9780 4200



PHOENIX

SPECIFICATIONS

GLOSS

SINK MIXER 200MM SQUARELINE

PRODUCT CODE:

GS731 CHR

FINISH:

CHROME

WELS:

5 STAR - 6.0 LT/MIN



PARTS LIST

1. GLOSS SINK BODY
2. 25MM CARTRIDGE
3. GLOSS SINK MIXER HANDLE
4. SINK MIXER
5. AERATOR
6. DRESS PLATE
7. O-RING
8. O-RING
9. SCREW CAP
10. GRUB SCREW KNURL END
11. GRUB SCREW M4X6
12. SPOUT BEARING
13. SCREW CAP
14. NYLON RING
15. SPOUT BEARING
16. M8X25 THREADED ROD
17. M8 NUT
18. FLEXIBLE HOSE 450MM COLD
19. FLEXIBLE HOSE 450MM HOT
20. FIXING PLATE
21. RUBBER FIXING PLATE
22. MIXER LOCK NUT
23. MIXER DOME
24. M3X6 SCREW

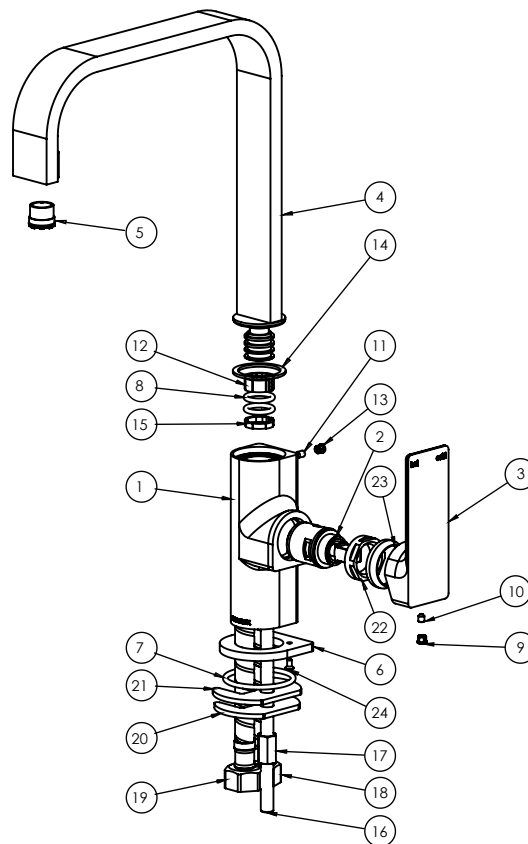

MAINTENANCE AND CARE:

- All surfaces should be cleaned with mild liquid detergent or soap and water.
- Do not use cream cleaners or citrus based cleaning products, as they are abrasive.
- Use of unsuitable cleaning agents may damage the surface. Any damage caused in this way will not be covered by warranty.

PACKAGING INCLUDES

- 1 x Sink mixer
- 1 x 450mm braided flexible cold hose
- 1 x 450mm braided flexible hot hose
- 1 x Installation kit
- 1 x Installation instructions
- 1 x Warranty card

PLEASE [CLICK HERE](#) TO VIEW FULL WARRANTY

While we aim to ensure the specifications shown are correct at time of printing, Phoenix Tapware reserves the right to make modifications without prior notice. Always use the physical product measurements for mark-ups and roughing-in as the line drawing shown may differ from the actual product over time. All measurements are shown in millimetres.

www.phoenixtapware.com.au
03 9780 4200