



# PHOENIX

## SPECIFICATIONS

### SUBI

### SIDE LEVER MIXER 200MM GOOSENECK

PRODUCT CODE: I0573103C  
 FINISH: CHROME  
 WELS: 4 STAR - 7 LT/MIN

#### INFORMATION:

TEMPERATURE RATING: MIN 1° - MAX 75°  
 PRESSURE RATING: MIN 150 kPa - MAX 500 kPa



AVAILABLE IN:



CHROME

FOR MORE INFORMATION VISIT  
[www.phoenixtapware.com.au](http://www.phoenixtapware.com.au)

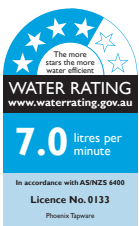
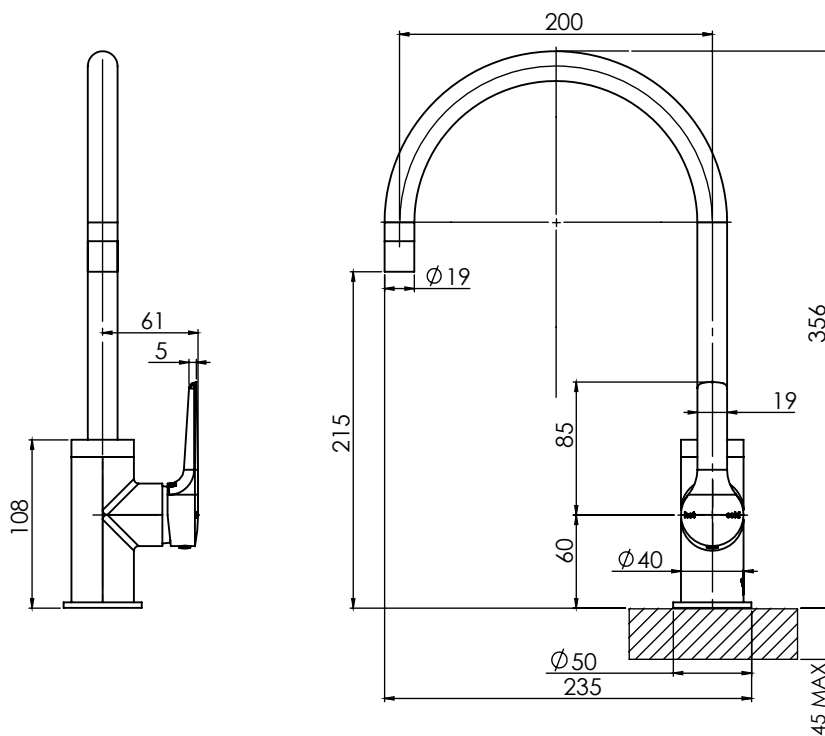

PLEASE [CLICK HERE TO VIEW FULL WARRANTY](#)

While we aim to ensure the specifications shown are correct at time of printing, Phoenix Tapware reserves the right to make modifications without prior notice. Always use the physical product measurements for mark-ups and roughing-in as the line drawing shown may differ from the actual product over time. All measurements are shown in millimetres.

Subi is a Registered Trademark of Phoenix Industries Pty. Ltd.

V291116

[www.phoenixtapware.com.au](http://www.phoenixtapware.com.au)  
03 9780 4200



# PHOENIX

## SPECIFICATIONS

### SUBI

## SIDE LEVER MIXER 200MM GOOSENECK

PRODUCT CODE: I0573103C  
 FINISH: CHROME  
 WELS: 4 STAR - 7 LT/MIN



### PARTS LIST

1. SIDE LEVER BODY
2. SPOUT BOSS
3. MIXER BODY COVER
4. LOWER SPOUT DISC
5. UPPER SPOUT DISC
6. BRAZED SPOUT ASSEMBLY
7. O-RING
8. O-RING
9. 35MM CARTRIDGE
10. MIXER LOCKNUT
11. MIXER DOME
12. SINK MIXER HANDLE
13. GRUB SCREW M5X6
14. AERATOR
15. AERATOR GASKET
16. NOZZLE RETAINER
17. M8X100 THREADED ROD
18. FIXING PLATE
19. RUBBER GASKET
20. M8 NUT
21. FLEXIBLE HOSE 450MM COLD
22. FLEXIBLE HOSE 450MM HOT
23. DRESS PLATE
24. M5 SCREW CAP
25. O-RING
26. O-RING

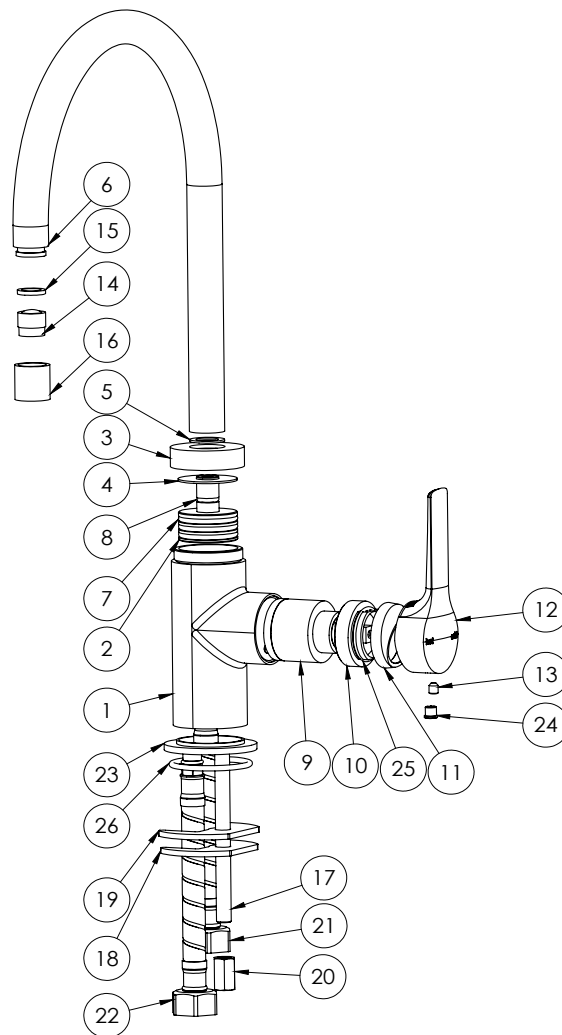

### MAINTENANCE AND CARE:

- Chrome plated surfaces should be cleaned with mild liquid detergent or soap and water.
- Do not use cream cleaners or citrus based cleaning products, as they are abrasive.
- Use of unsuitable cleaning agents may damage the surface. Any damage caused in this way will not be covered by warranty.

### PACKAGING INCLUDES

- 1 x Mixer body
- 1 x Mixer spout
- 1 x Dress plate
- 1 x 450mm braided flexible cold hose
- 1 x 450mm braided flexible hot hose
- 1 x AF11 spanner
- 1 x Installation kit
- 1 x Installation instructions
- 1 x Warranty card

PLEASE [CLICK HERE TO VIEW FULL WARRANTY](#)

While we aim to ensure the specifications shown are correct at time of printing, Phoenix Tapware reserves the right to make modifications without prior notice. Always use the physical product measurements for mark-ups and roughing-in as the line drawing shown may differ from the actual product over time. All measurements are shown in millimetres.

Subi is a Registered Trademark of Phoenix Industries Pty. Ltd.

V291116

[www.phoenixtapware.com.au](http://www.phoenixtapware.com.au)  
03 9780 4200