



PHOENIX

SPECIFICATIONS

NARA

VESSEL MIXER

PRODUCT CODE: 101-7900-00
 FINISH: CHROME
 WELS: 5 STAR - 5.0 LT/MIN

INFORMATION:

TEMPERATURE RATING: MIN 1° - MAX 75°
 PRESSURE RATING: MIN 150 kPa - MAX 500 kPa



AVAILABLE IN:



CHROME

FOR MORE INFORMATION VISIT
www.phoenixtapware.com.au

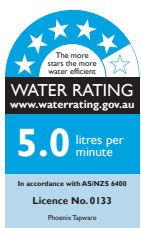
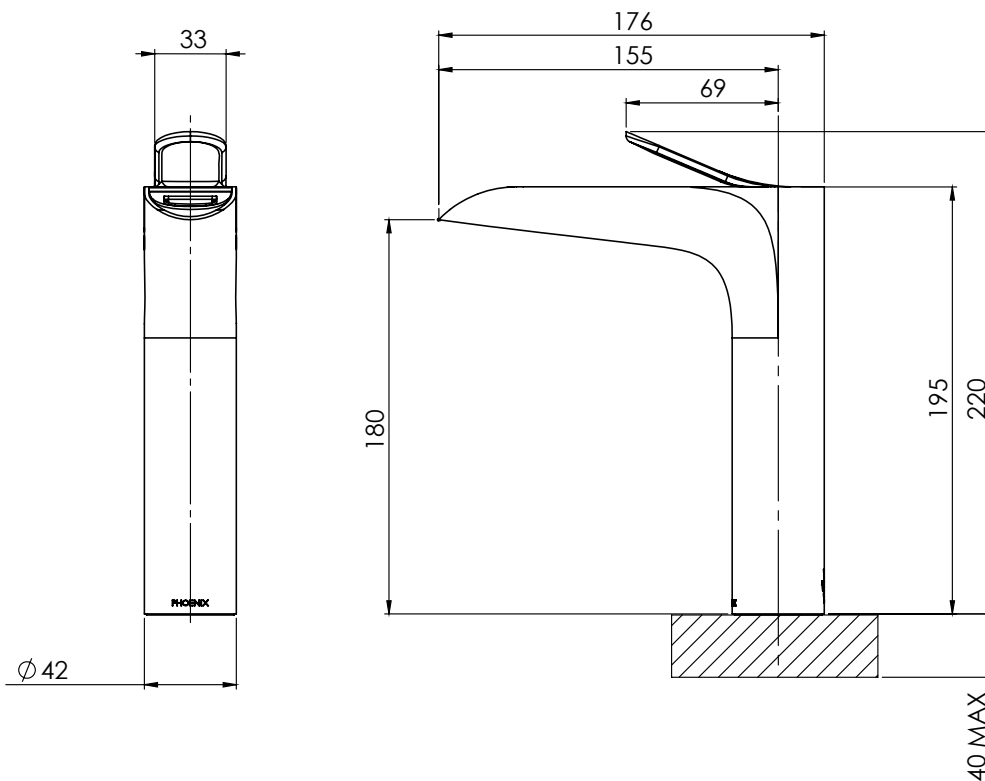

PLEASE [CLICK HERE](#) TO VIEW FULL WARRANTY

While we aim to ensure the specifications shown are correct at time of printing, Phoenix Tapware reserves the right to make modifications without prior notice. Always use the physical product measurements for mark-ups and roughing-in as the line drawing shown may differ from the actual product over time. All measurements are shown in millimetres.

A Registered Design and Trademark of Phoenix Industries Pty. Ltd
V201216

www.phoenixtapware.com.au
03 9780 4200



PHOENIX

SPECIFICATIONS

NARA

VESSEL MIXER

PRODUCT CODE: 101-7900-00
 FINISH: CHROME
 WELS: 5 STAR - 5.0 LT/MIN



PARTS LIST

1. MIXER BODY
2. STEM GLIDER
3. 35MM CARTRIDGE
4. LOCKNUT
5. CARTRIDGE SEAT
6. RETAINER
7. AERATOR
8. O-RING 9X2.0 MM
9. O-RING 27X2.0MM
10. O-RING 25X2.5MM
11. FLOW PIN
12. O-RING 4X1.5MM
13. SCREW SOCKET
14. SCREW
15. O-RING ID16XT2.5
16. LEVER
17. 450MM FLEXIBLE HOSE HOT
18. 450MM FLEXIBLE HOSE COLD
19. INDICATOR TAPE
20. COVER PLATE
21. M6 THREADED ROD
22. M6 THREADED NUT
23. MOUNTING PLATE
24. MOUNTING GASKET
25. GRUB SCREW M3X5
26. BASIN SEALING WASHER
27. PIVOT WASHER
28. SEALING WASHER
29. MIXER TOP FIXTURE

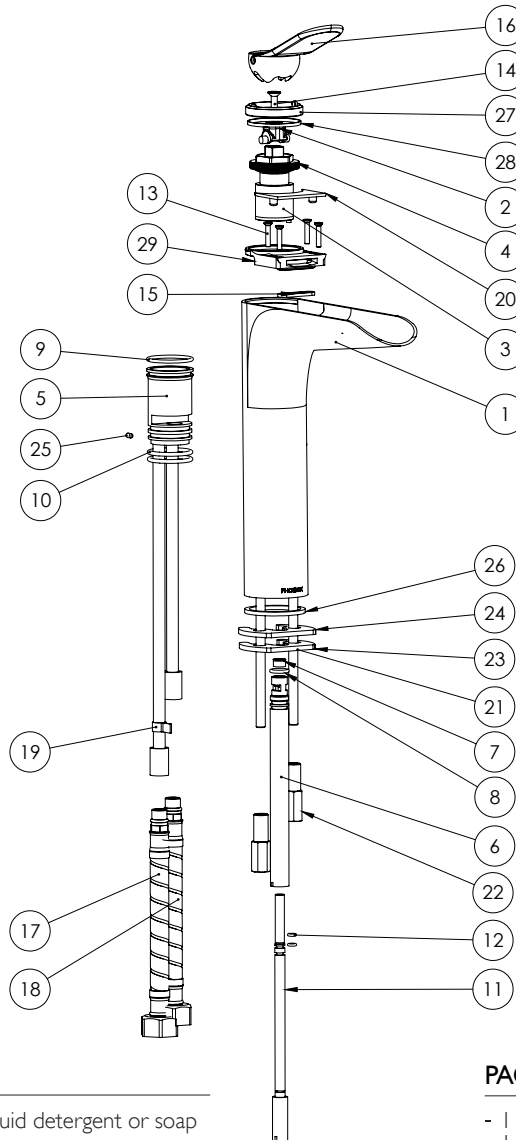

MAINTENANCE AND CARE:

- All surfaces should be cleaned with mild liquid detergent or soap and water.
- Do not use cream cleaners or citrus based cleaning products, as they are abrasive.
- Use of unsuitable cleaning agents may damage the surface. Any damage caused in this way will not be covered by warranty.

PACKAGING INCLUDES

- 1 x Vessel mixer
- 1 x Installation kit
- 1 x 450mm braided flexible cold hose
- 1 x 450mm braided flexible hot hose
- 1 x Installation instructions
- 1 x Warranty card

PLEASE [CLICK HERE TO VIEW FULL WARRANTY](#)

While we aim to ensure the specifications shown are correct at time of printing, Phoenix Tapware reserves the right to make modifications without prior notice. Always use the physical product measurements for mark-ups and roughing-in as the line drawing shown may differ from the actual product over time. All measurements are shown in millimetres.

A Registered Design and Trademark of Phoenix Industries Pty. Ltd
 V201216

www.phoenixtapware.com.au
 03 9780 4200