



# PHOENIX

## SPECIFICATIONS

### NARA

### WALL BASIN OUTLET 185MM

PRODUCT CODE:	101-7610-00
FINISH:	CHROME
WELS:	4 STAR - 6.5 LT/MIN

#### INFORMATION:

TEMPERATURE RATING:	MIN 1° - MAX 75°
PRESSURE RATING:	MIN 150 kPa - MAX 500 kPa



AVAILABLE IN:



CHROME

FOR MORE INFORMATION VISIT  
[www.phoenixtapware.com.au](http://www.phoenixtapware.com.au)

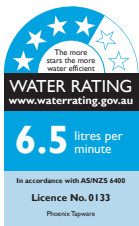
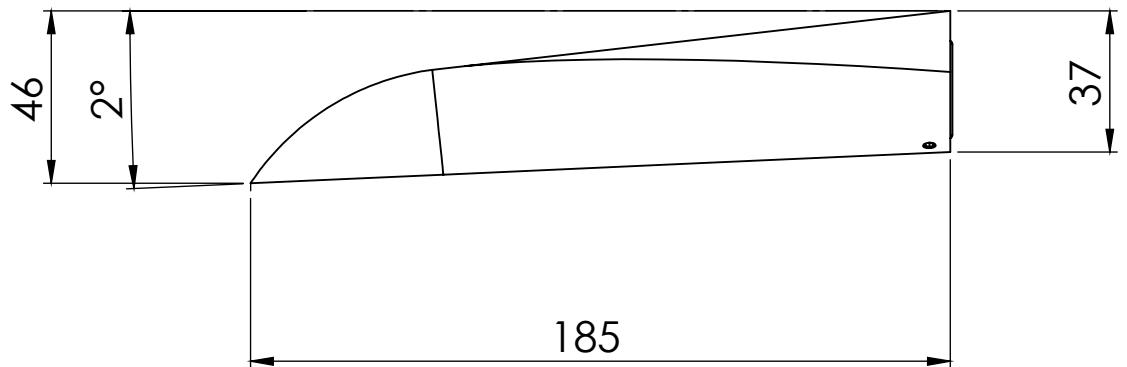
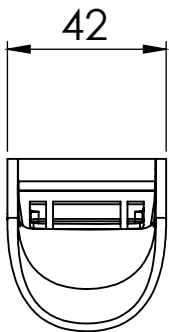

PLEASE [CLICK HERE](#) TO VIEW FULL WARRANTY

While we aim to ensure the specifications shown are correct at time of printing, Phoenix Tapware reserves the right to make modifications without prior notice. Always use the physical product measurements for mark-ups and roughing-in as the line drawing shown may differ from the actual product over time. All measurements are shown in millimetres.

A Registered Design and Trademark of Phoenix Industries Pty. Ltd  
V201216

[www.phoenixtapware.com.au](http://www.phoenixtapware.com.au)  
03 9780 4200



# PHOENIX

SPECIFICATIONS

**NARA**

## WALL BASIN OUTLET 185MM

PRODUCT CODE: 101-7610-00  
FINISH: CHROME  
WELS: 4 STAR - 6.5 LT/MIN



### PARTS LIST

1. WALL OUTLET
2. WALL ADAPTER
3. GRUB SCREW
4. O-RING 22X2.0MM
5. O-RING 23X2.5MM
6. AERATOR
7. WASHER
8. WATER FLOW
9. WATER FLOW COVER
10. SEAL BAFFLE
11. SCREW M3X12

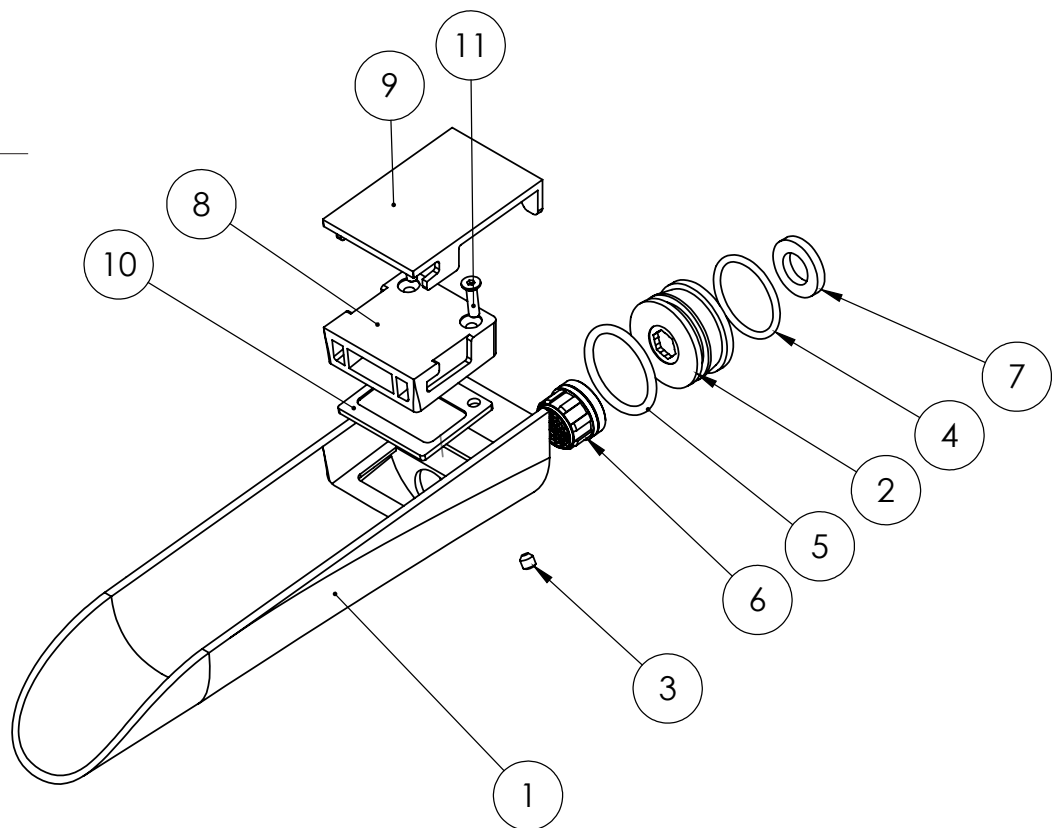

### MAINTENANCE AND CARE:

- All surfaces should be cleaned with mild liquid detergent or soap and water.
- Do not use cream cleaners or citrus based cleaning products, as they are abrasive.
- Use of unsuitable cleaning agents may damage the surface. Any damage caused in this way will not be covered by warranty.

### PACKAGING INCLUDES

- 1 x Wall outlet
- 1 x Installation kit
- 1 x Installation instructions
- 1 x Warranty card

PLEASE [CLICK HERE](#) TO VIEW FULL WARRANTY

While we aim to ensure the specifications shown are correct at time of printing, Phoenix Tapware reserves the right to make modifications without prior notice. Always use the physical product measurements for mark-ups and roughing-in as the line drawing shown may differ from the actual product over time. All measurements are shown in millimetres.

A Registered Design and Trademark of Phoenix Industries Pty. Ltd.

V201216

[www.phoenixtapware.com.au](http://www.phoenixtapware.com.au)  
03 9780 4200