

# RUSH

## RUSH HIGH-RISE SHOWER ARM

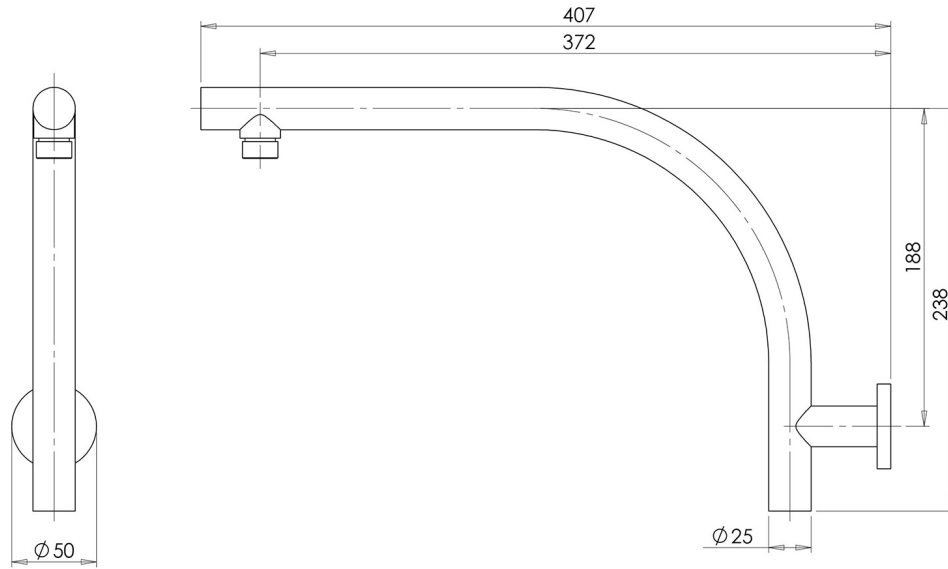

## SPECIFICATIONS



### AVAILABLE IN



RU522 CHR  
Chrome



RU522 BN  
Brushed  
Nickel



RU522 GM  
Gun Metal



RU522 MB  
Matte Black



RU522-12  
Brushed  
Gold

### INFORMATION

Temperature Rating  
1 - 75°C

Pressure Rating  
150 - 500kPa



### MAINTENANCE AND CARE:

- All surfaces should be cleaned with mild liquid detergent or soap and water.
- Do not use cream cleaners or citrus based cleaning products, as they are abrasive.
- Use of unsuitable cleaning agents may damage the surface.
- Any damage caused in this way will not be covered by warranty.

Please visit <https://www.phoenixtapware.com.au/warranty> to view the full warranty