



PHOENIX

SPECIFICATIONS

MEKKO

WALL BASIN / BATH MIXER SET 200MM

PRODUCT CODE: 115-7810-10
 FINISH: MATTE BLACK
 WELS: 5 STAR - 6.0 LT/MIN

INFORMATION:

TEMPERATURE RATING: MIN 1° - MAX 75°
 PRESSURE RATING: MIN 150 kPa - MAX 500 kPa



AVAILABLE IN:



FOR MORE INFORMATION VISIT
www.phoenixtapware.com.au

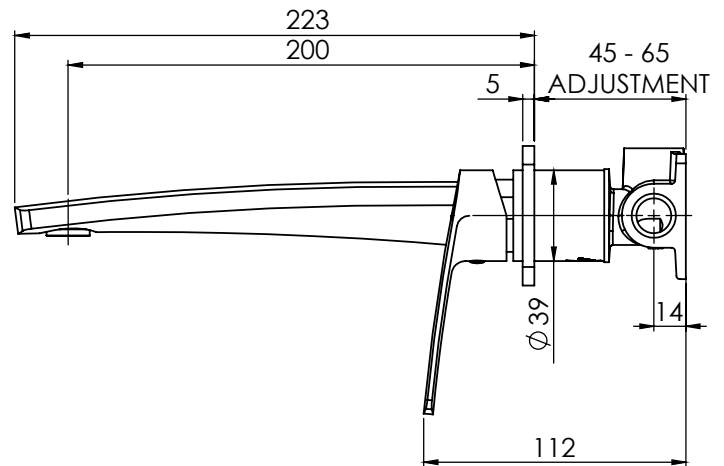
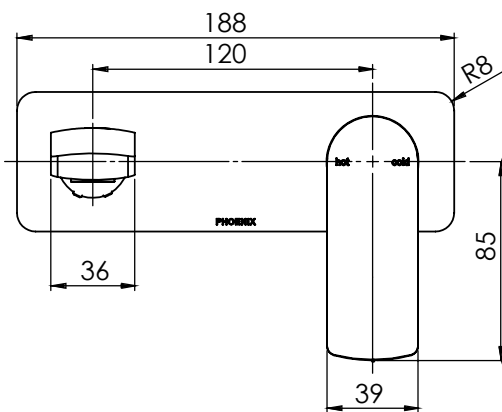

PLEASE [CLICK HERE TO VIEW FULL WARRANTY](#)

While we aim to ensure the specifications shown are correct at time of printing, Phoenix Tapware reserves the right to make modifications without prior notice. Always use the physical product measurements for mark-ups and roughing-in as the line drawing shown may differ from the actual product over time. All measurements are shown in millimetres.

Designed and Registered in Australia by Phoenix Industries Pty. Ltd
 V190618

www.phoenixtapware.com.au
 03 9780 4200



PHOENIX

SPECIFICATIONS

MEKKO

WALL BASIN / BATH MIXER SET 200MM

PRODUCT CODE:

115-7810-10

FINISH:

MATTE BLACK

WELS:

5 STAR - 6.0 LT/MIN



PARTS LIST

1. WALL BREACH
2. 35MM CARTRIDGE
3. DOME
4. SLEEVE
5. O-RING 33X2.0
6. DRESS PLATE
7. ADAPTOR
8. O-RING 13X2.6
9. O-RING 21X1.9
10. SPOUT
11. M4 GRUB SCREW
12. O-RING 39X2.5
13. HANDLE
14. GRUB SCREW M5X5
15. M4 SCREW CAP
16. AERATOR 7LT/MIN
17. MAX FLOW AERATOR

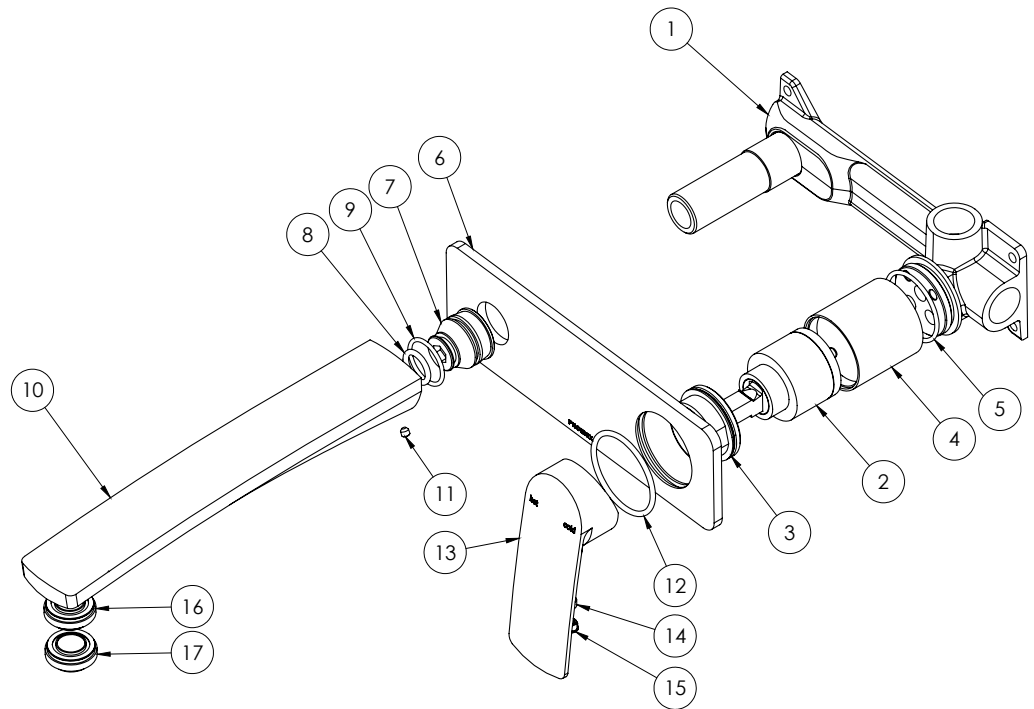

MAINTENANCE AND CARE:

- All surfaces should be cleaned with mild liquid detergent or soap and water.
- Do not use cream cleaners or citrus based cleaning products, as they are abrasive.
- Use of unsuitable cleaning agents may damage the surface. Any damage caused in this way will not be covered by warranty.

PACKAGING INCLUDES

- 1 x Wall breach
- 1 x Dress plate
- 1 x Handle
- 1 x Spout
- 1 x Installation kit
- 1 x Installation instructions
- 1 x Warranty card

PLEASE [CLICK HERE](#) TO VIEW FULL WARRANTY

While we aim to ensure the specifications shown are correct at time of printing, Phoenix Tapware reserves the right to make modifications without prior notice. Always use the physical product measurements for mark-ups and roughing-in as the line drawing shown may differ from the actual product over time. All measurements are shown in millimetres.

Designed and Registered in Australia by Phoenix Industries Pty. Ltd

V190618

www.phoenixtapware.com.au
03 9780 4200