



PHOENIX

SPECIFICATIONS

TOI

BASIN MIXER

PRODUCT CODE: 108-7700-10
 FINISH: MATTE BLACK
 WELS: 5 STAR - 6.0 LT/MIN

INFORMATION:

TEMPERATURE RATING: MIN 1° - MAX 75°
 PRESSURE RATING: MIN 150 kPa - MAX 500 kPa



ALSO AVAILABLE IN:

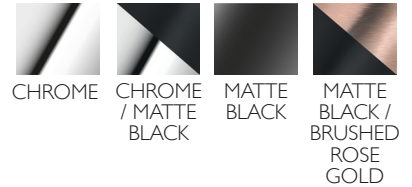

FOR MORE INFORMATION VISIT www.phoenixtapware.com.au

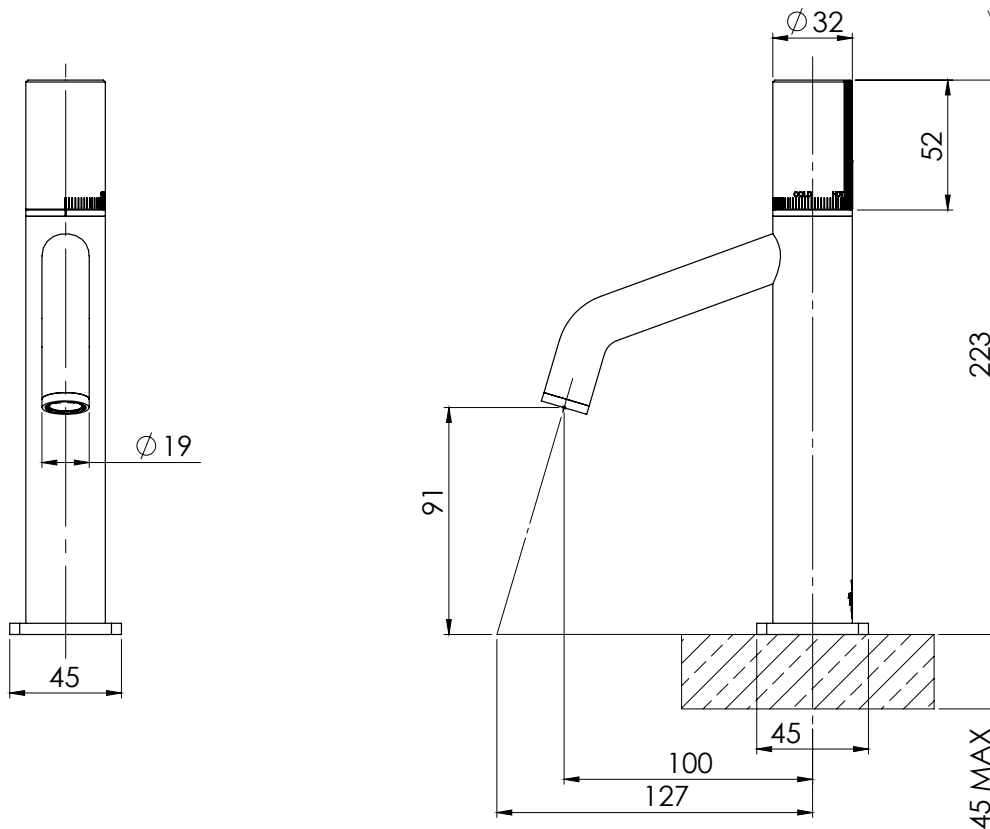

PLEASE [CLICK HERE TO VIEW FULL WARRANTY](#)

While we aim to ensure the specifications shown are correct at time of printing, Phoenix Tapware reserves the right to make modifications without prior notice. Always use the physical product measurements for mark-ups and roughing-in as the line drawing shown may differ from the actual product over time. All measurements are shown in millimetres.

Toi is a Registered Trademark of Phoenix Industries Pty. Ltd.

V6022020

www.phoenixtapware.com.au
03 9780 4200



PHOENIX

SPECIFICATIONS

TOI

BASIN MIXER

PRODUCT CODE: 108-7700-10
 FINISH: MATTE BLACK
 WELS: 5 STAR - 6.0 LT/MIN



PARTS LIST

1. MIXER BODY
2. 25MM PROGRESSIVE CARTRIDGE
3. LOCKNUT
4. MIXER RING
5. DRESS RING
6. HANDLE WASHER
7. HANDLE
8. AERATOR RETAINER
9. O-RING 14X1.0MM
10. AERATOR
11. HOSE EXTENSION HOT
12. HOSE EXTENSION COLD
13. DRESS PLATE
14. M8 THREADED ROD
15. FLEXIBLE HOSE 450MM HOT
16. FLEXIBLE HOSE 450MM COLD
17. FIXING PLATE
18. M8 NUT
19. FIXING PLATE RUBBER
20. RUBBER WASHER
21. GRUB SCREW M5X5
22. SCREW
23. CARTRIDGE EXTENSION
24. GRUB SCREW CAP
25. RED INDICATOR TAPE

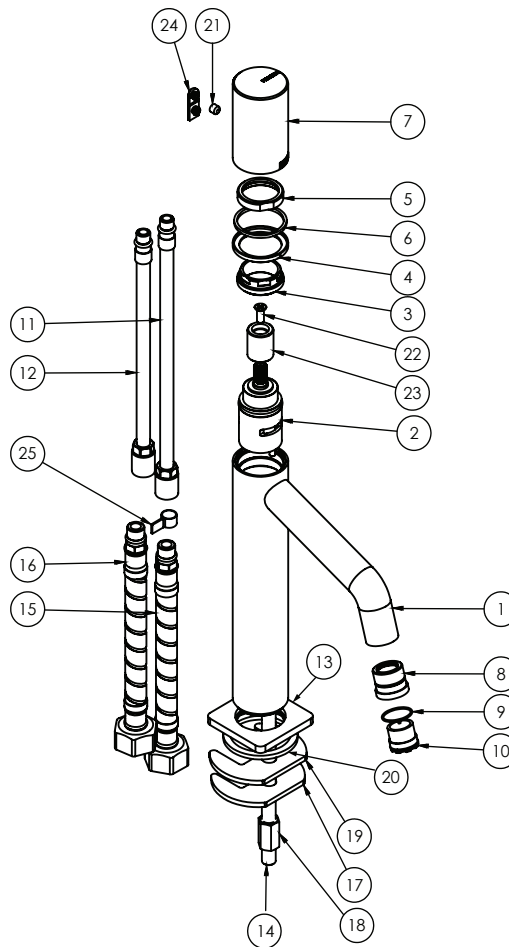

MAINTENANCE AND CARE:

- All surfaces should be cleaned with mild liquid detergent or soap and water.
- Do not use cream cleaners or citrus based cleaning products, as they are abrasive.
- Use of unsuitable cleaning agents may damage the surface. Any damage caused in this way will not be covered by warranty.

PLEASE [CLICK HERE](#) TO VIEW FULL WARRANTY

While we aim to ensure the specifications shown are correct at time of printing, Phoenix Tapware reserves the right to make modifications without prior notice. Always use the physical product measurements for mark-ups and roughing-in as the line drawing shown may differ from the actual product over time. All measurements are shown in millimetres.

Toi is a Registered Trademark of Phoenix Industries Pty. Ltd.

www.phoenixtapware.com.au
 03 9780 4200