



# PHOENIX

## SPECIFICATIONS

**TOI**

**VESSEL MIXER**

PRODUCT CODE: 108-7900-10  
 FINISH: MATTE BLACK  
 WELS: 5 STAR - 6.0 LT/MIN

**INFORMATION:**

TEMPERATURE RATING: MIN 1° - MAX 75°  
 PRESSURE RATING: MIN 150 kPa - MAX 500 kPa



ALSO AVAILABLE IN:



FOR MORE INFORMATION VISIT [www.phoenixtapware.com.au](http://www.phoenixtapware.com.au)

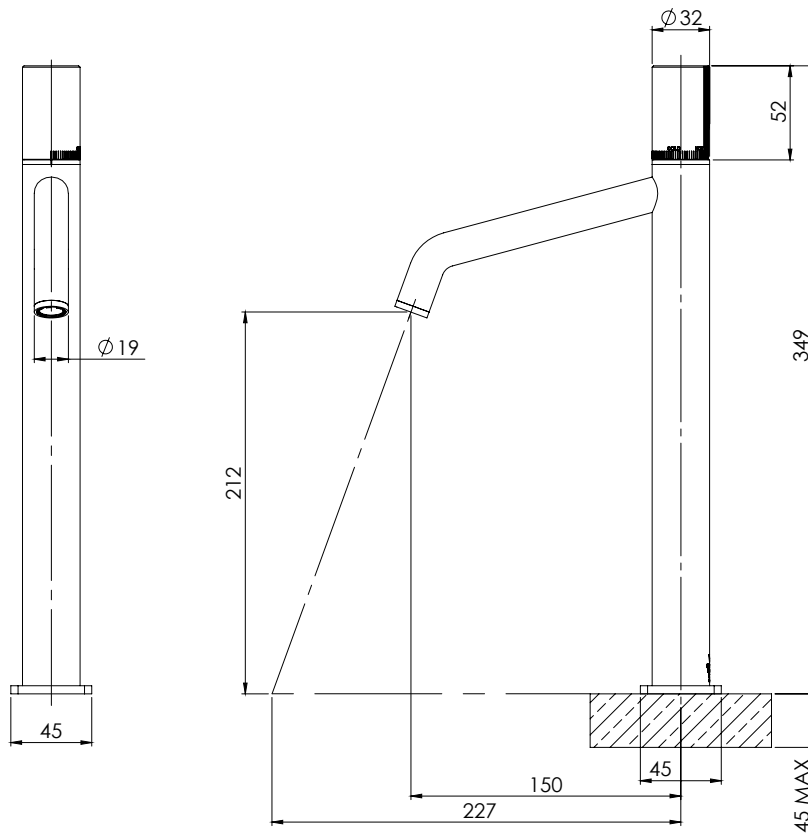

PLEASE [CLICK HERE](#) TO VIEW FULL WARRANTY

While we aim to ensure the specifications shown are correct at time of printing, Phoenix Tapware reserves the right to make modifications without prior notice. Always use the physical product measurements for mark-ups and roughing-in as the line drawing shown may differ from the actual product over time. All measurements are shown in millimetres.

Toi is a Registered Trademark of Phoenix Industries Pty Ltd  
V6022020

[www.phoenixtapware.com.au](http://www.phoenixtapware.com.au)  
03 9780 4200



# PHOENIX

## SPECIFICATIONS

TOI

### VESSEL MIXER

PRODUCT CODE:

108-7900-10

FINISH:

MATTE BLACK

WELS:

5 STAR - 6.0 LT/MIN



#### PARTS LIST

1. MIXER BODY
2. 25MM PROGRESSIVE CARTRIDGE
3. LOCKNUT
4. MIXER RING
5. DRESS RING NUT
6. HANDLE WASHER
7. HANDLE
8. AERATOR RETAINER
9. AERATOR
10. HOSE EXTENSION HOT
11. HOSE EXTENSION COLD
12. DRESS PLATE
13. FLEXIBLE HOSE 450MM HOT
14. FLEXIBLE HOSE 450MM COLD
15. RUBBER WASHER
16. GRUB SCREW M5X5
17. THREADED TAIL
18. LOCKNUT GASKET
19. LOCKNUT PLASTIC
20. LOCKNUT SPACER
21. CARTRIDGE EXTENSION
22. SCREW
23. GRUB SCREW CAP
24. O-RING 14X1.0MM

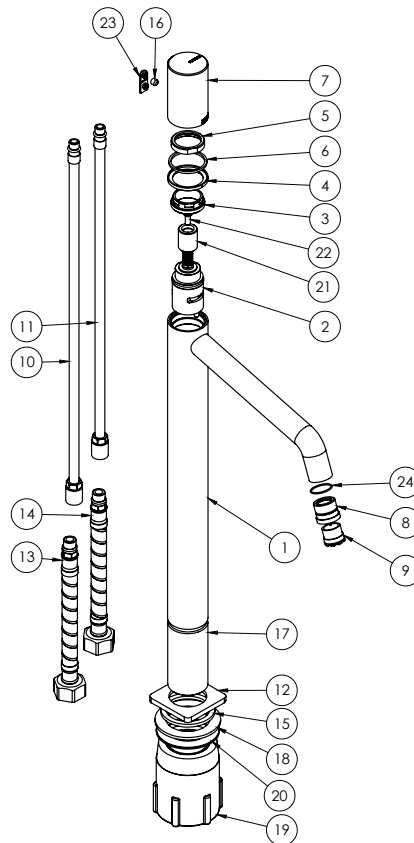

#### MAINTENANCE AND CARE:

- All surfaces should be cleaned with mild liquid detergent or soap and water.
- Do not use cream cleaners or citrus based cleaning products, as they are abrasive.
- Use of unsuitable cleaning agents may damage the surface. Any damage caused in this way will not be covered by warranty.

PLEASE [CLICK HERE](#) TO VIEW FULL WARRANTY

While we aim to ensure the specifications shown are correct at time of printing, Phoenix Tapware reserves the right to make modifications without prior notice. Always use the physical product measurements for mark-ups and roughing-in as the line drawing shown may differ from the actual product over time. All measurements are shown in millimetres.

Toi is a Registered Trademark of Phoenix Industries Pty. Ltd

[www.phoenixtapware.com.au](http://www.phoenixtapware.com.au)  
03 9780 4200