



PHOENIX

SPECIFICATIONS

TOI

WALL TOP ASSEMBLIES

PRODUCT CODE:	108-0600-60
FINISH:	CHROME / BLACK
WELS:	N/A
INFORMATION:	
TEMPERATURE RATING:	MIN 1° - MAX 75°
PRESSURE RATING:	MIN 150 kPa - MAX 500 kPa

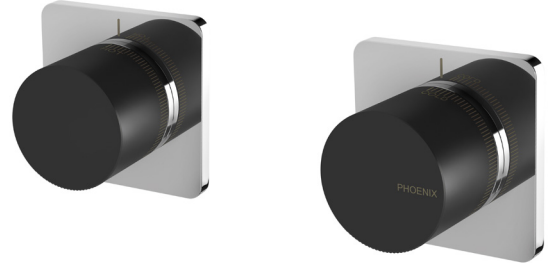

ALSO AVAILABLE IN:



FOR MORE INFORMATION VISIT www.phoenixtapware.com.au

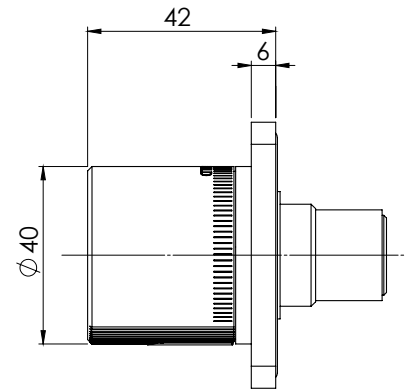
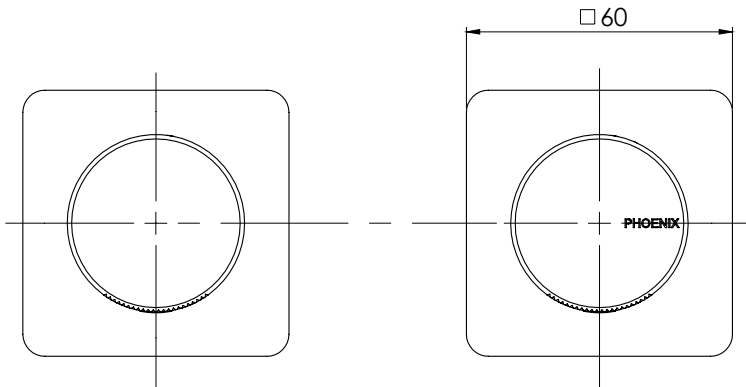

PLEASE [CLICK HERE TO VIEW FULL WARRANTY](#)

While we aim to ensure the specifications shown are correct at time of printing, Phoenix Tapware reserves the right to make modifications without prior notice. Always use the physical product measurements for mark-ups and roughing-in as the line drawing shown may differ from the actual product over time. All measurements are shown in millimetres.

A Registered Design and Trademark of Phoenix Industries Pty. Ltd
V6022020

www.phoenixtapware.com.au
03 9780 4200



TOI

WALL TOP ASSEMBLIES

PRODUCT CODE:

108-0600-60

FINISH:

CHROME / BLACK

WELS:

N/A

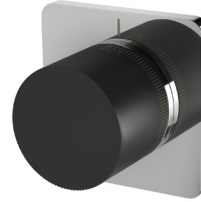

PARTS LIST

1. 57MM CARTRIDGE
2. FIBER WASHER
3. TOP BONNET
4. SPINDLE
5. SCREW
6. BACK PLATE
7. O-RING 50X3.0MM
8. LOCKNUT
9. WASHER
10. HANDLE
11. GRUB SCREW M5X0.8
12. SCREW CAP

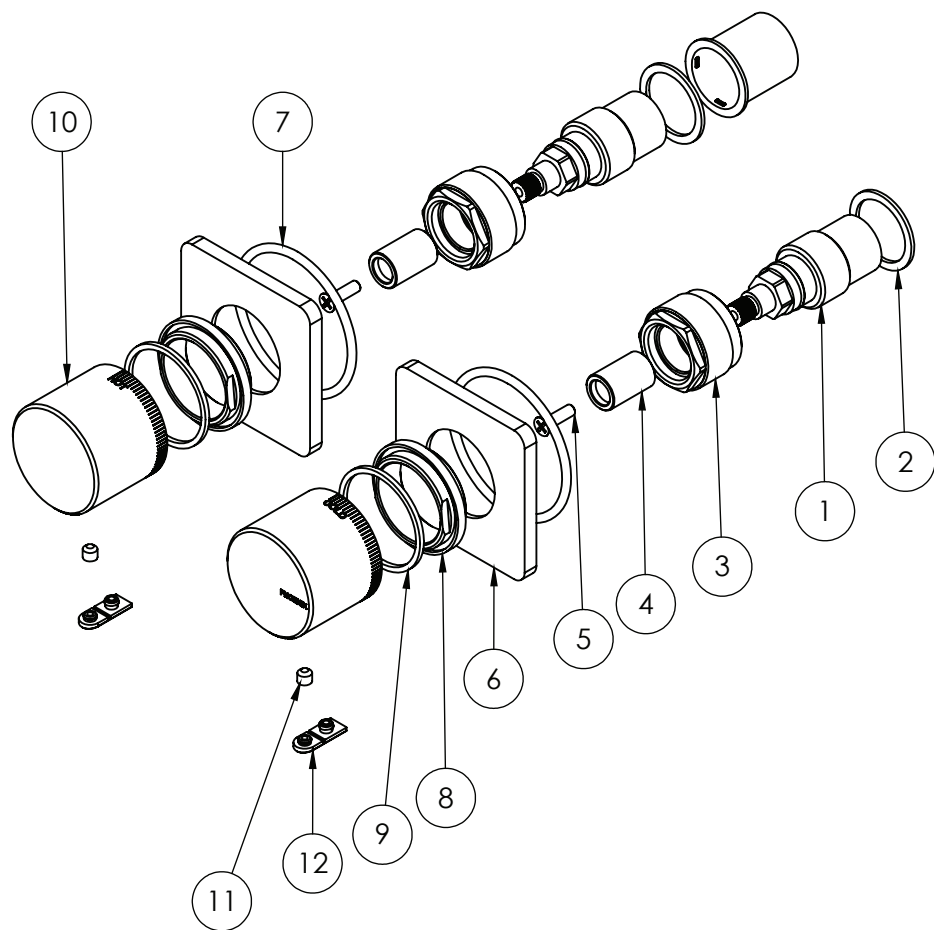

MAINTENANCE AND CARE:

- All surfaces should be cleaned with mild liquid detergent or soap and water.
- Do not use cream cleaners or citrus based cleaning products, as they are abrasive.
- Use of unsuitable cleaning agents may damage the surface. Any damage caused in this way will not be covered by warranty.

PLEASE [CLICK HERE TO VIEW FULL WARRANTY](#)

While we aim to ensure the specifications shown are correct at time of printing, Phoenix Tapware reserves the right to make modifications without prior notice. Always use the physical product measurements for mark-ups and roughing-in as the line drawing shown may differ from the actual product over time. All measurements are shown in millimetres.

A Registered Design and Trademark of Phoenix Industries Pty. Ltd
V6022020

www.phoenixtapware.com.au
03 9780 4200