

IVY MKII
SINK MIXER SWIVEL

PRODUCT CODE: 154-7300-00
 FINISH: CHROME
 WELS: 4 STAR - 6.5 LT/MIN

INFORMATION:

TEMPERATURE RATING: MIN 1° - MAX 75°
 PRESSURE RATING: MIN 150 kPa - MAX 500 kPa

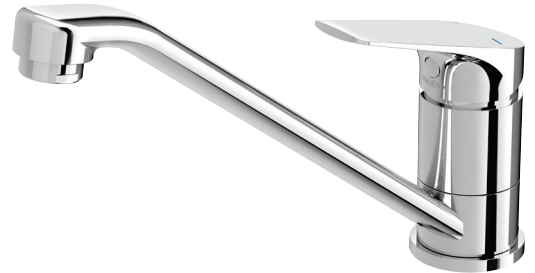

AVAILABLE IN:



CHROME

FOR MORE INFORMATION VISIT
www.phoenixtapware.com.au

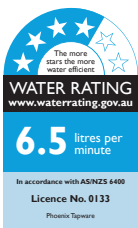
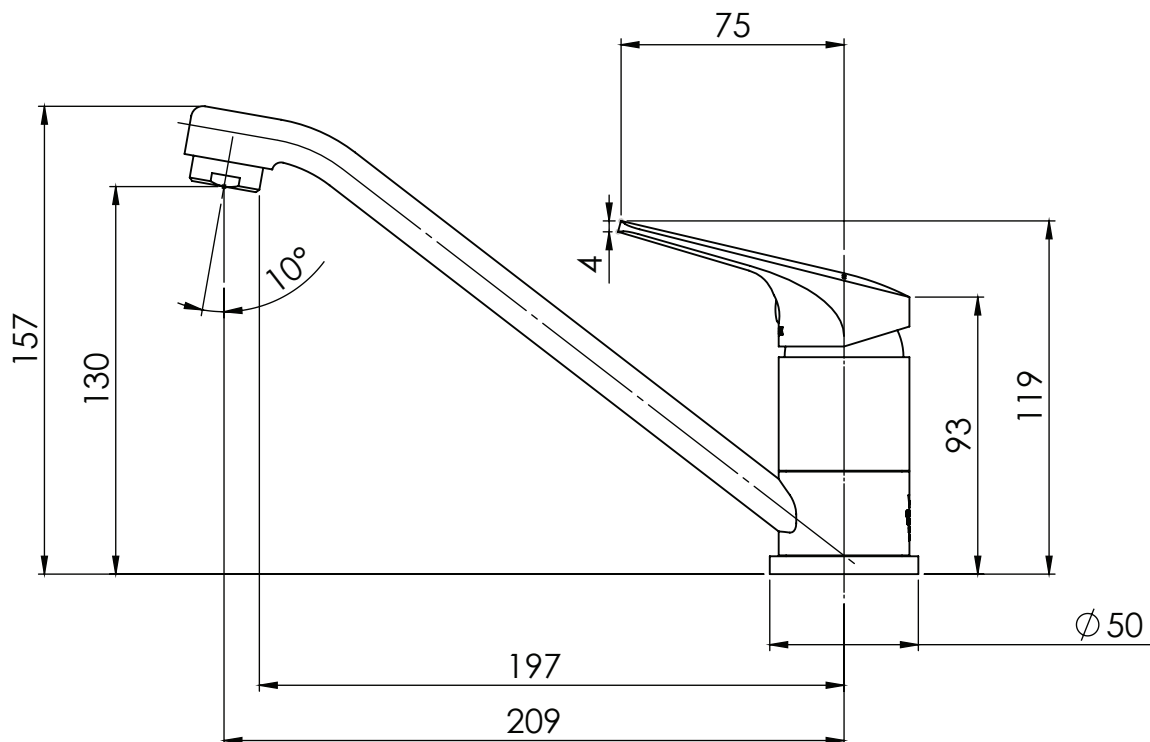

PLEASE [CLICK HERE](#) TO VIEW FULL WARRANTY

While we aim to ensure the specifications shown are correct at time of printing, Phoenix Tapware reserves the right to make modifications without prior notice. Always use the physical product measurements for mark-ups and roughing-in as the line drawing shown may differ from the actual product over time. All measurements are shown in millimetres.

www.phoenixtapware.com.au
 03 9780 4200

IVY MKII

SINK MIXER SWIVEL

PRODUCT CODE: 154-7300-00
 FINISH: CHROME
 WELS: 4 STAR - 6.5 LT/MIN

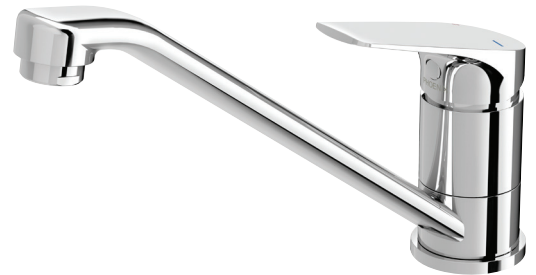

PARTS LIST

1. MIXER BODY
2. MIXER HANDLE
3. DRESS PLATE
4. O-RING 37X3MM
5. CARTRIDGE SEAT
6. MIXER SEAL
7. MIXER SPOUT
8. AERATOR HOUSING
9. THREADED ROD M8X75MM
10. THREADED NUT
11. FLEXIBLE HOSE 450MM COLD
12. FLEXIBLE HOSE 450MM HOT
13. RUBBER GASKET
14. FIXING PLATE
15. TEFLON BEARING
16. GRUB SCREW M5X6
17. SCREW CAP
18. AERATOR
19. AERATOR WASHER
20. 35MM CARTRIDGE
21. MIXER DOME
22. CARTRIDGE LOCKNUT

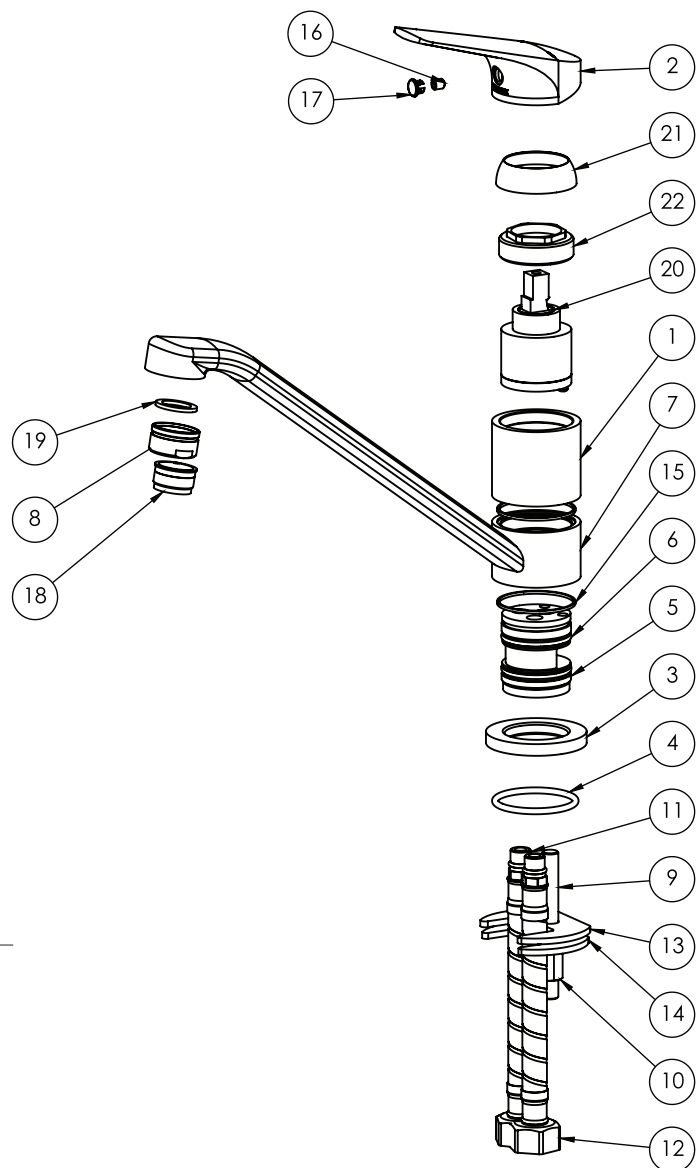

MAINTENANCE AND CARE:

- All surfaces should be cleaned with mild liquid detergent or soap and water.
- Do not use cream cleaners or citrus based cleaning products, as they are abrasive.
- Use of unsuitable cleaning agents may damage the surface. Any damage caused in this way will not be covered by warranty.

PLEASE [CLICK HERE TO VIEW FULL WARRANTY](#)

While we aim to ensure the specifications shown are correct at time of printing, Phoenix Tapware reserves the right to make modifications without prior notice. Always use the physical product measurements for mark-ups and roughing-in as the line drawing shown may differ from the actual product over time. All measurements are shown in millimetres.

www.phoenixtapware.com.au
03 9780 4200