



# PHOENIX

## SPECIFICATIONS

### VIVID SLIMLINE OVAL

### FLOOR MOUNTED BATH MIXER

PRODUCT CODE: VV745-10  
 FINISH: MATTE BLACK  
 WELS: N/A

#### INFORMATION:

TEMPERATURE RATING: MIN 1° - MAX 75°  
 PRESSURE RATING: MIN 150 kPa - MAX 500 kPa



AVAILABLE IN:

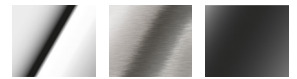

CHROME BRUSHED NICKEL MATTE BLACK

FOR MORE INFORMATION VISIT  
[www.phoenixtapware.com.au](http://www.phoenixtapware.com.au)

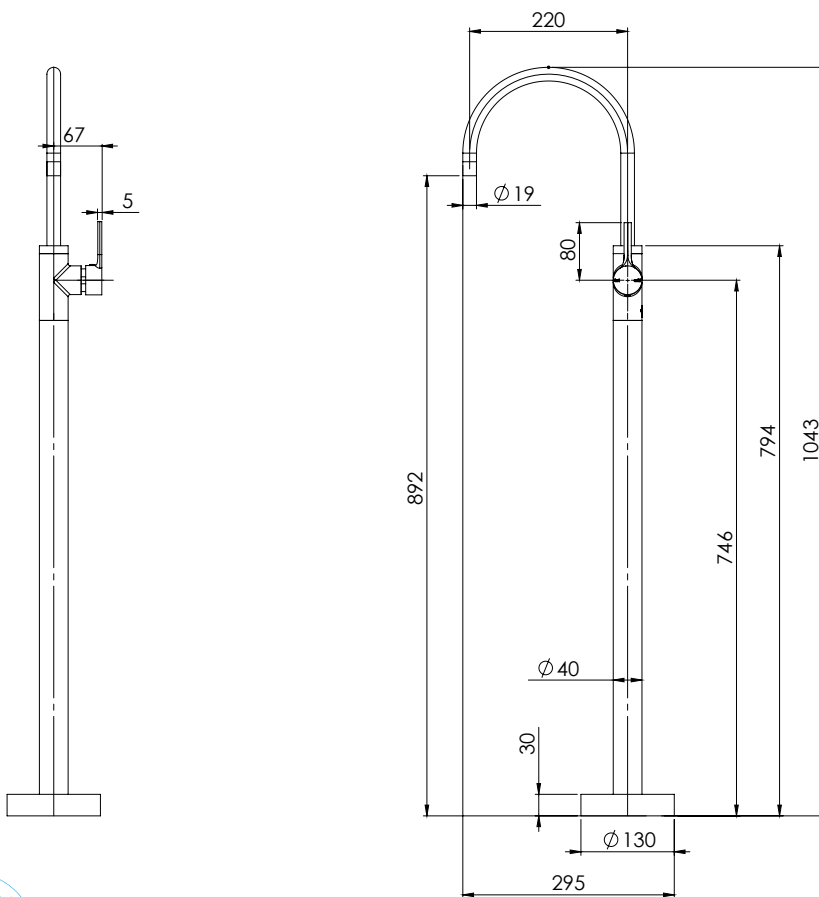

PLEASE [CLICK HERE](#) TO VIEW FULL WARRANTY

While we aim to ensure the specifications shown are correct at time of printing, Phoenix Tapware reserves the right to make modifications without prior notice. Always use the physical product measurements for mark-ups and roughing-in as the line drawing shown may differ from the actual product over time. All measurements are shown in millimetres.

[www.phoenixtapware.com.au](http://www.phoenixtapware.com.au)  
 03 9780 4200



# PHOENIX

## SPECIFICATIONS

### VIVID SLIMLINE OVAL

### FLOOR MOUNTED BATH MIXER

PRODUCT CODE:

VV745-10

FINISH:

MATTE BLACK

WELS:

N/A



#### PARTS LIST

1. MOUNT PLATE
2. MIXER TUBE
3. MIXER COVER PLATE
4. SIDE LEVER MIXER ASSY
5. HOSE EXTENSION M10MM
6. UPPER TUBE ADAPTER
7. SCREW
8. FLEXIBLE HOSE 750MM HOT
9. FLEXIBLE HOSE 750MM COLD
10. O-RING 40X2.5MM
11. GRUB SCREW M5X4MM

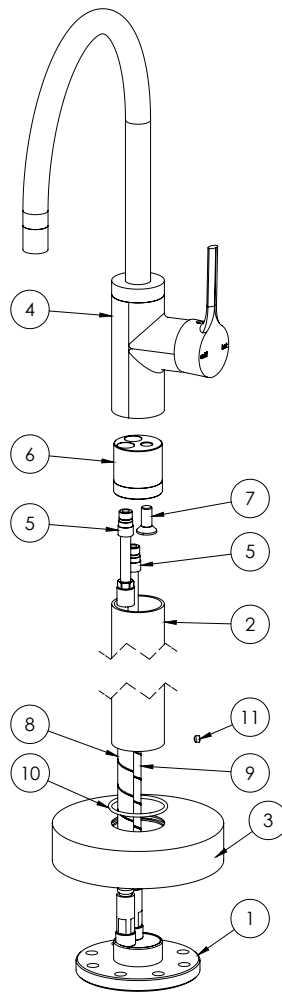

#### MAINTENANCE AND CARE:

- All surfaces should be cleaned with mild liquid detergent or soap and water.
- Do not use cream cleaners or citrus based cleaning products, as they are abrasive.
- Use of unsuitable cleaning agents may damage the surface. Any damage caused in this way will not be covered by warranty.

#### PACKAGING INCLUDES

- 1 x Floor mounted mixer
- 1 x Installation kit
- 1 x 450mm braided flexible cold hose
- 1 x 450mm braided flexible hot hose
- 1 x Installation instructions
- 1 x Warranty card

PLEASE [CLICK HERE](#) TO VIEW FULL WARRANTY

While we aim to ensure the specifications shown are correct at time of printing, Phoenix Tapware reserves the right to make modifications without prior notice. Always use the physical product measurements for mark-ups and roughing-in as the line drawing shown may differ from the actual product over time. All measurements are shown in millimetres.

[www.phoenixtapware.com.au](http://www.phoenixtapware.com.au)  
03 9780 4200