



PHOENIX

SPECIFICATIONS

VIVID SLIMLINE

SHOWER / WALL MIXER 60MM BACKPLATE

PRODUCT CODE: VS7801-30
 FINISH: GUN METAL
 WELS: N/A

INFORMATION:

TEMPERATURE RATING: MIN 1° - MAX 55°
 PRESSURE RATING: MIN 150 kPa - MAX 500 kPa



AVAILABLE IN:

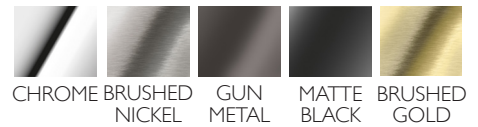

FOR MORE INFORMATION VISIT
www.phoenixtapware.com

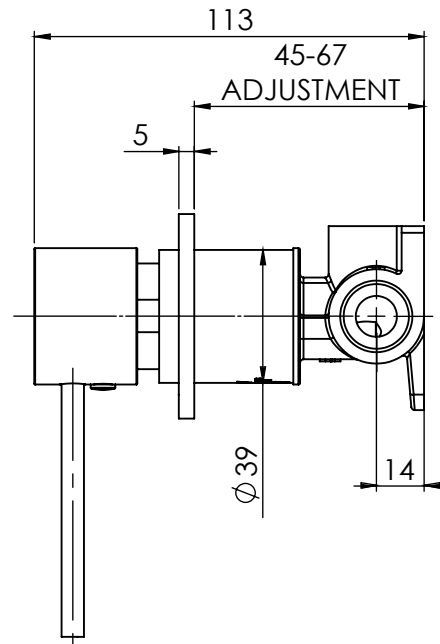
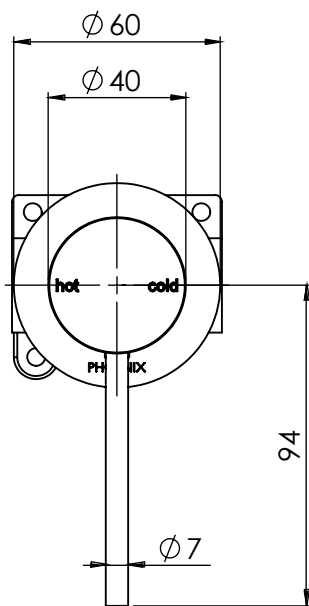

PLEASE [CLICK HERE TO VIEW FULL WARRANTY](#)

While we aim to ensure the specifications shown are correct at time of printing, Phoenix Tapware reserves the right to make modifications without prior notice. Always use the physical product measurements for mark-ups and roughing-in as the line drawing shown may differ from the actual product over time. All measurements are shown in millimetres. Some colours may vary across product types due to differing construction materials. Printed images are a representation only and the colour or finish may vary from the actual product.
 A Registered Design and Trademark of Phoenix Industries Pty. Ltd

www.phoenixtapware.com.au
 03 9780 4200



PHOENIX

SPECIFICATIONS

VIVID SLIMLINE

SHOWER / WALL MIXER 60MM BACKPLATE

PRODUCT CODE:

VS7801-30

FINISH:

GUN METAL

WELS:

N/A



PARTS LIST

1. WALL MIXER SLEEVE
2. WALL MIXER BODY
3. CARTRIDGE
4. O-RING
5. LOCKNUT DOME SLEEVE
6. GRUB SCREW M5 X 5
7. SCREW CAP
8. SHOWER MIXER HANDLE
9. MIXER LEVER PIN
10. O-RING
11. SHOWER MIXER BACKPLATE

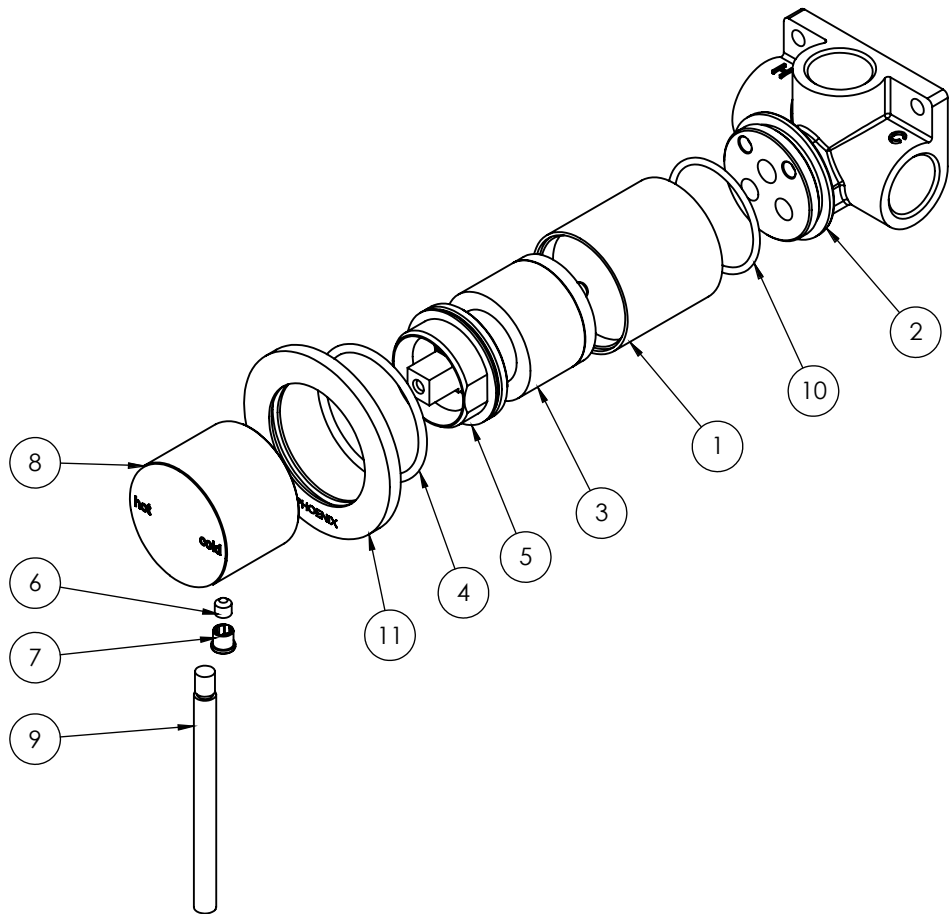

MAINTENANCE AND CARE:

- All surfaces should be cleaned with mild liquid detergent or soap and water.
- Do not use cream cleaners or citrus based cleaning products, as they are abrasive.
- Use of unsuitable cleaning agents may damage the surface. Any damage caused in this way will not be covered by warranty.

PLEASE [CLICK HERE](#) TO VIEW FULL WARRANTY

While we aim to ensure the specifications shown are correct at time of printing, Phoenix Tapware reserves the right to make modifications without prior notice. Always use the physical product measurements for mark-ups and roughing-in as the line drawing shown may differ from the actual product over time. All measurements are shown in millimetres. Some colours may vary across product types due to differing construction materials. Printed images are a representation only and the colour or finish may vary from the actual product.
A Registered Design and Trademark of Phoenix Industries Pty. Ltd

www.phoenixtapware.com.au
03 9780 4200