

### VIVID SLIMLINE UP

### SHOWER / WALL MIXER

PRODUCT CODE: 112-7800-40  
 FINISH: BRUSHED NICKEL  
 WELS: N/A

#### INFORMATION:

TEMPERATURE RATING: MIN 1° - MAX 75°  
 PRESSURE RATING: MIN 150 kPa - MAX 500 kPa



AVAILABLE IN:

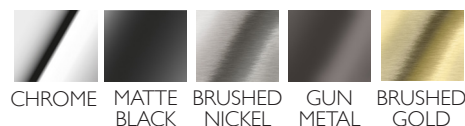

FOR MORE INFORMATION VISIT  
[www.phoenixtapware.com.au](http://www.phoenixtapware.com.au)

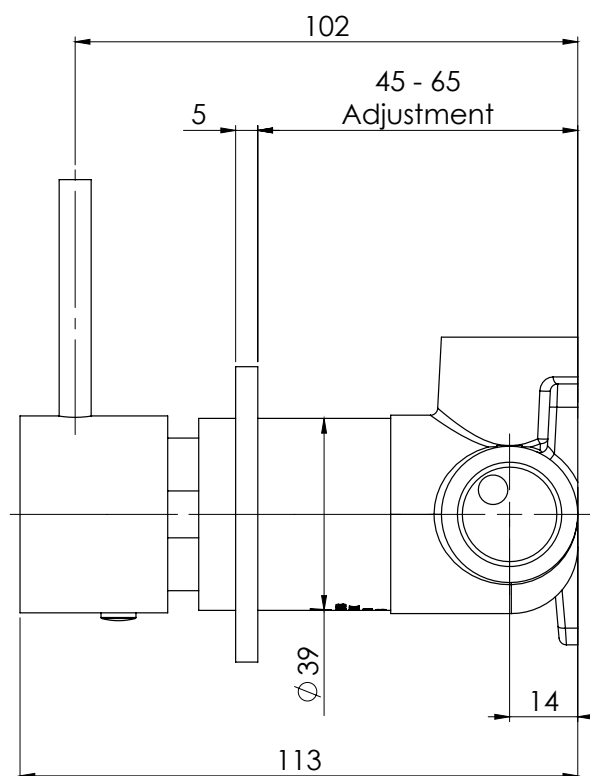
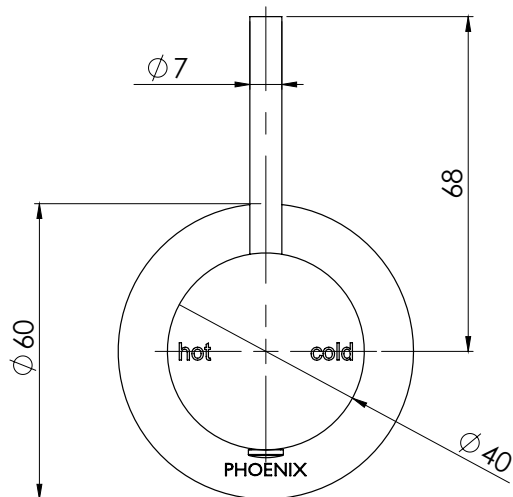

PLEASE [CLICK HERE TO VIEW FULL WARRANTY](#)

While we aim to ensure the specifications shown are correct at time of printing, Phoenix Tapware reserves the right to make modifications without prior notice. Always use the physical product measurements for mark-ups and roughing-in as the line drawing shown may differ from the actual product over time. All measurements are shown in millimetres.

[www.phoenixtapware.com.au](http://www.phoenixtapware.com.au)  
 03 9780 4200



### VIVID SLIMLINE UP

### SHOWER / WALL MIXER

PRODUCT CODE:

112-7800-40

FINISH:

BRUSHED NICKEL

WELS:

N/A



#### PARTS LIST

1. WALL MIXER BODY
2. 35MM CARTRIDGE
3. LOCKNUT
4. O-RING 33X2.0MM
5. MIXER SLEEVE
6. SCREW
7. O-RING 39X2.5MM
8. LEVER PIN
9. HANDLE
10. DRESS PLATE
11. SCREW CAP
12. GRUB SCREW M5X5

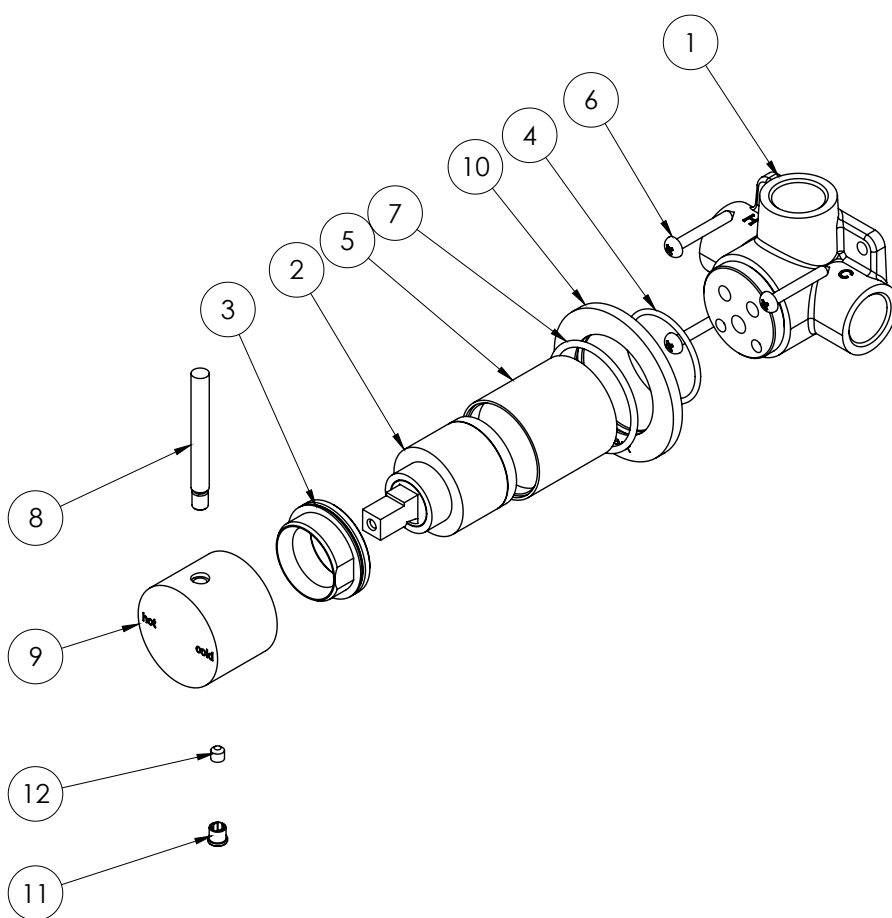

#### MAINTENANCE AND CARE:

- All surfaces should be cleaned with mild liquid detergent or soap and water.
- Do not use cream cleaners or citrus based cleaning products, as they are abrasive.
- Use of unsuitable cleaning agents may damage the surface. Any damage caused in this way will not be covered by warranty.

#### PACKAGING INCLUDES

- 1 x Shower mixer
- 1 x Handle
- 1 x Dress plate
- 1 x Installation kit
- 1 x Installation instructions
- 1 x Warranty card

PLEASE [CLICK HERE](#) TO VIEW FULL WARRANTY

While we aim to ensure the specifications shown are correct at time of printing, Phoenix Tapware reserves the right to make modifications without prior notice. Always use the physical product measurements for mark-ups and roughing-in as the line drawing shown may differ from the actual product over time. All measurements are shown in millimetres.

[www.phoenixtapware.com.au](http://www.phoenixtapware.com.au)  
03 9780 4200