



PHOENIX

SPECIFICATIONS

VIVID SLIMLINE

WALL SHOWER SYSTEM

PRODUCT CODE: VS7490-10
 FINISH: MATTE BLACK
 WELS: 3 STAR - 8 LT/MIN

INFORMATION:

TEMPERATURE RATING: MIN 1° - MAX 75°
 PRESSURE RATING: MIN 150 kPa - MAX 500 kPa



AVAILABLE IN:



FOR MORE INFORMATION VISIT
www.phoenixtapware.com.au

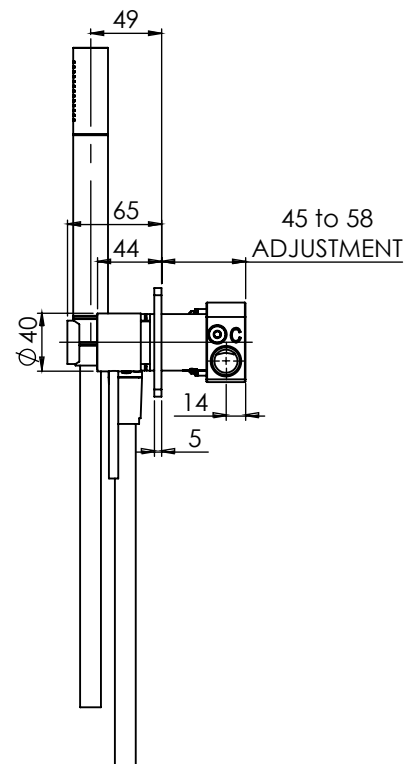
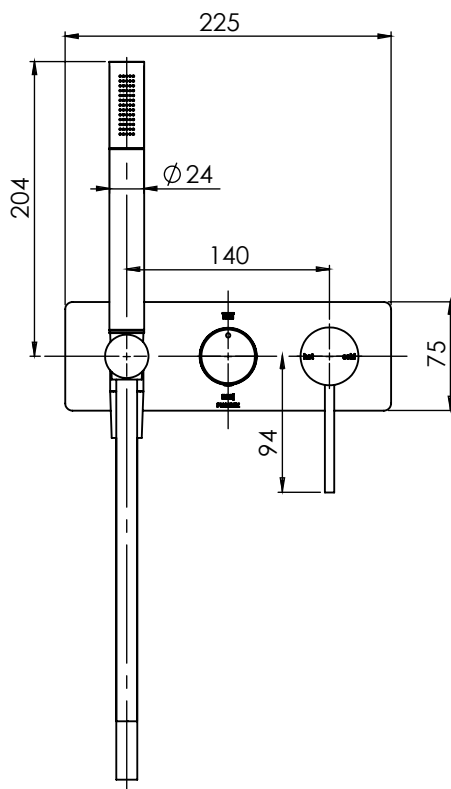

PLEASE [CLICK HERE TO VIEW FULL WARRANTY](#)

While we aim to ensure the specifications shown are correct at time of printing, Phoenix Tapware reserves the right to make modifications without prior notice. Always use the physical product measurements for mark-ups and roughing-in as the line drawing shown may differ from the actual product over time. All measurements are shown in millimetres. Some colours may vary across product types due to differing construction materials. Printed images are a representation only and the colour or finish may vary from the actual product.

www.phoenixtapware.com.au
 03 9780 4200



VIVID SLIMLINE

WALL SHOWER SYSTEM

PRODUCT CODE:

VS7490-10

FINISH:

MATTE BLACK

WELS:

3 STAR - 8 LT/MIN



PARTS LIST

1. WALL BREACH
2. O-RING
3. WALL MIXER SLEEVE
4. 35MM CARTRIDGE
5. LOCK NUT DOME
6. TWO WAY DIVERTER
7. DIVERTER LOCKNUT
8. DIVERTER SLEEVE
9. DRESS PLATE
10. O-RING
11. SHOWER MIXER HANDLE
12. MIXER LEVER PIN
13. GRUB SCREW M5X5
14. SCREW CAP
15. DIVERTER ADAPTOR
16. DIVERTER HANDLE
17. WALL SPOUT ADAPTOR
18. O-RING
19. SHOWER BRACKET ASSEMBLY
20. AERATOR
21. SHOWER HAND HOSE ASSEMBLY
22. TEST CAP
23. PROTECTIVE COVER
24. ALLEN KEY
25. WOOD SCREWS M4 X35

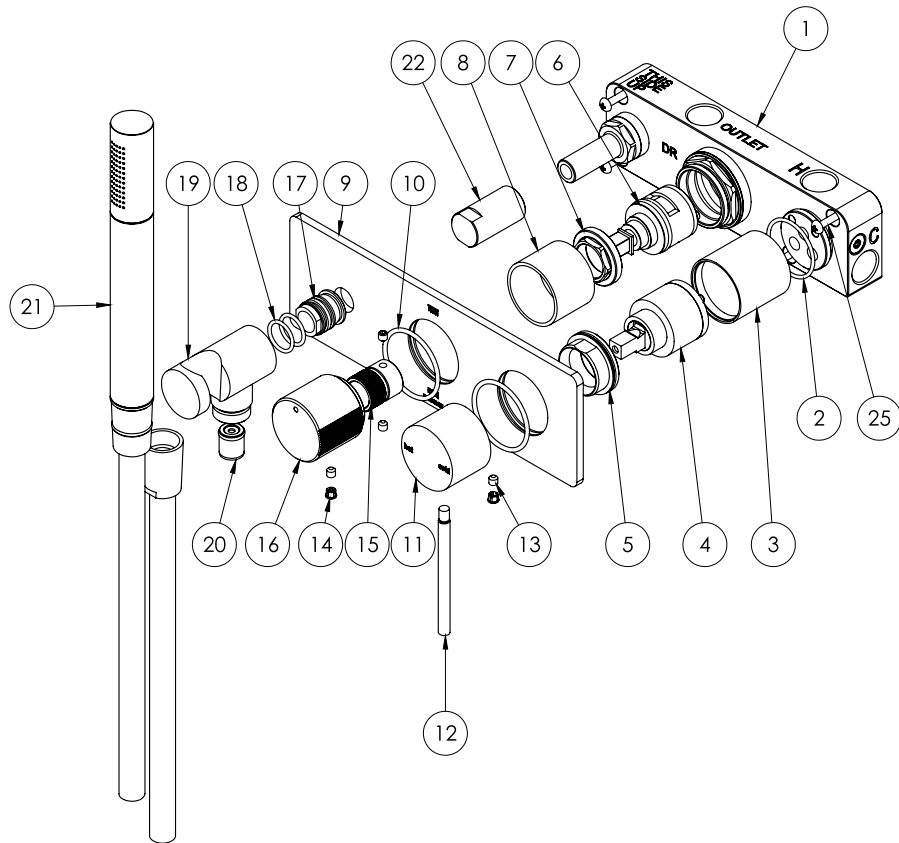

MAINTENANCE AND CARE:

- All surfaces should be cleaned with mild liquid detergent or soap and water.
- Do not use cream cleaners or citrus based cleaning products, as they are abrasive.
- Use of unsuitable cleaning agents may damage the surface. Any damage caused in this way will not be covered by warranty.

PLEASE [CLICK HERE](#) TO VIEW FULL WARRANTY

While we aim to ensure the specifications shown are correct at time of printing, Phoenix Tapware reserves the right to make modifications without prior notice. Always use the physical product measurements for mark-ups and roughing-in as the line drawing shown may differ from the actual product over time. All measurements are shown in millimetres. Some colours may vary across product types due to differing construction materials. Printed images are a representation only and the colour or finish may vary from the actual product.

www.phoenixtapware.com.au

03 9780 4200