



PHOENIX

SPECIFICATIONS

AXIA

WALL BASIN / BATH MIXER SET 200MM

PRODUCT CODE: 117-7810-40
 FINISH: BRUSHED NICKEL
 WELS: 5 STAR - 6LT/MIN

INFORMATION:

TEMPERATURE RATING: MIN 1° - MAX 55°
 PRESSURE RATING: MIN 150 kPa - MAX 500 kPa



AVAILABLE IN:



FOR MORE INFORMATION VISIT
www.phoenixtapware.com

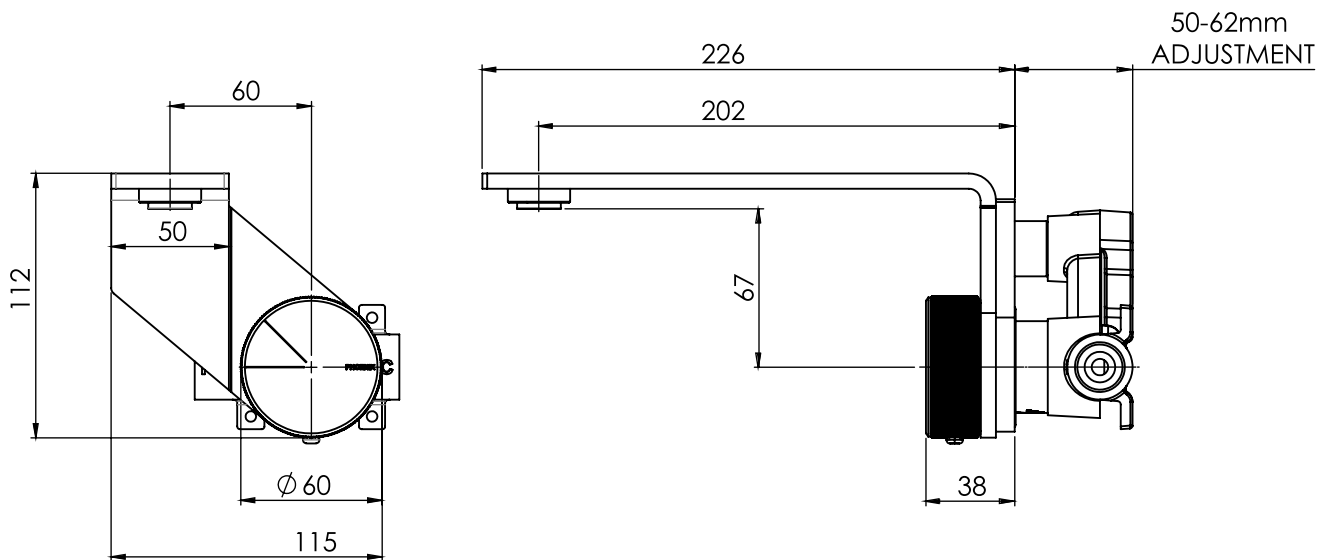

PLEASE [CLICK HERE TO VIEW FULL WARRANTY](#)

While we aim to ensure the specifications shown are correct at time of printing, Phoenix Tapware reserves the right to make modifications without prior notice. Always use the physical product measurements for mark-ups and roughing-in as the line drawing shown may differ from the actual product over time. All measurements are shown in millimetres. Some colours may vary across product types due to differing construction materials. Printed images are a representation only and the colour or finish may vary from the actual product.
 A Registered Design and Trademark of Phoenix Industries Pty. Ltd

www.phoenixtapware.com.au
 03 9780 4200



PHOENIX

SPECIFICATIONS

AXIA

WALL BASIN / BATH MIXER SET 200MM

PRODUCT CODE:

117-7810-40

FINISH:

BRUSHED NICKEL

WELS:

5 STAR - 6LT/MIN

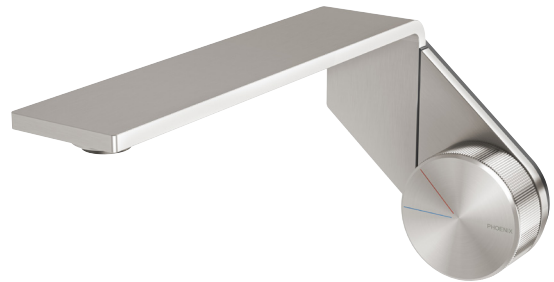

PARTS LIST

1. BREACH ASSEMBLY
2. LEVEL STAND
3. 33MM PROGRESSIVE CARTRIDGE
4. O-RING
5. CARTRIDGE LOCKNUT
6. BACK PLATE ASSEMBLY
7. LOCKNUT
8. SCREW
9. SPINDLE EXTENSION
10. SPINDLE ADAPTOR
11. O-RING
12. FRONT INDICATOR COVER
13. GRUB SCREW
14. SCREW M4X10MM
15. BASIN AERATOR
16. FREE FLOW AERATOR
17. SPOUT ADAPTOR

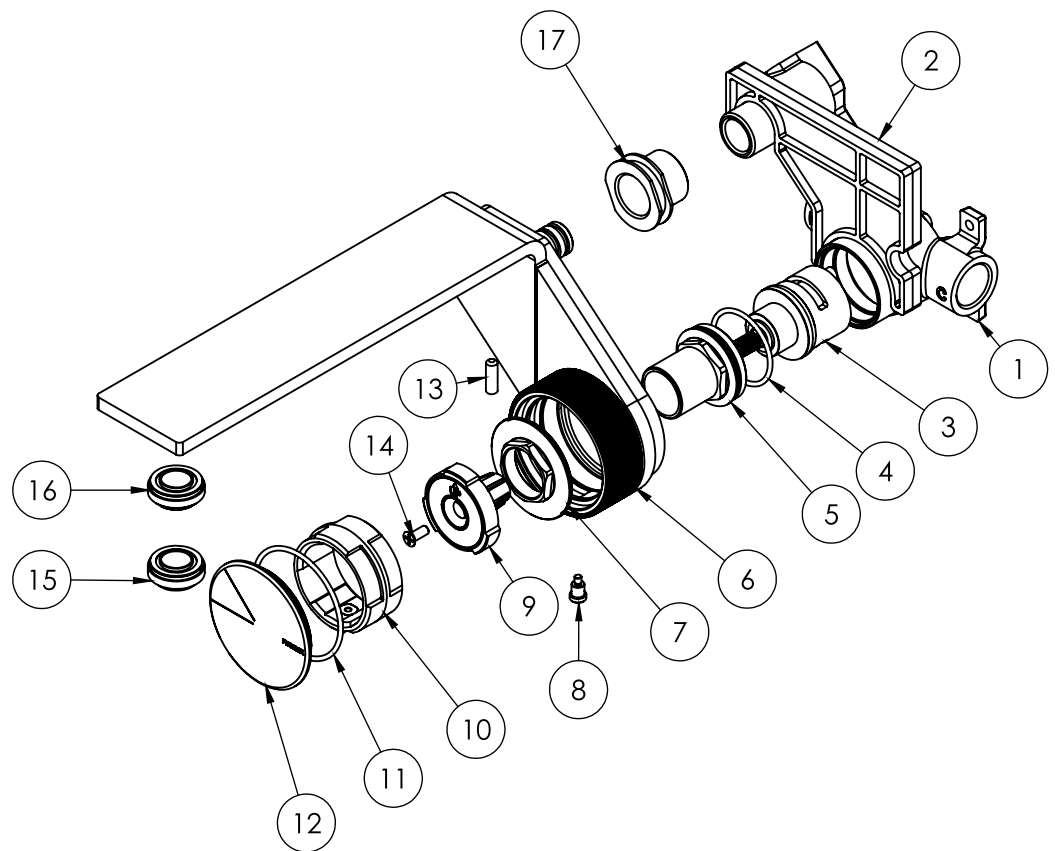

MAINTENANCE AND CARE:

- All surfaces should be cleaned with mild liquid detergent or soap and water.
- Do not use cream cleaners or citrus based cleaning products, as they are abrasive.
- Use of unsuitable cleaning agents may damage the surface. Any damage caused in this way will not be covered by warranty.

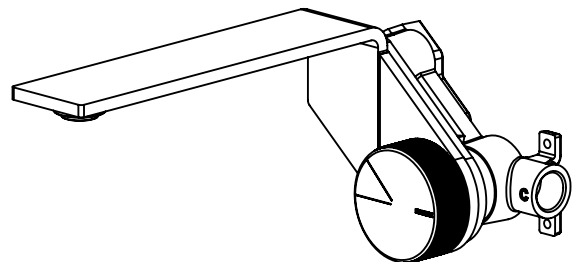

[PLEASE CLICK HERE TO VIEW FULL WARRANTY](#)

While we aim to ensure the specifications shown are correct at time of printing, Phoenix Tapware reserves the right to make modifications without prior notice. Always use the physical product measurements for mark-ups and roughing-in as the line drawing shown may differ from the actual product over time. All measurements are shown in millimetres. Some colours may vary across product types due to differing construction materials. Printed images are a representation only and the colour or finish may vary from the actual product.

A Registered Design and Trademark of Phoenix Industries Pty. Ltd

V261119

www.phoenixtapware.com.au

03 9780 4200