



PHOENIX

SPECIFICATIONS

RUSH

SINK MIXER

PRODUCT CODE:

RU730-40

FINISH:

BRUSHED NICKEL

WELS:

5 STAR - 5.5 LT/MIN



ALSO AVAILABLE IN:



CHROME MATTE BLACK

FOR MORE INFORMATION VISIT
www.phoenixtapware.com.au

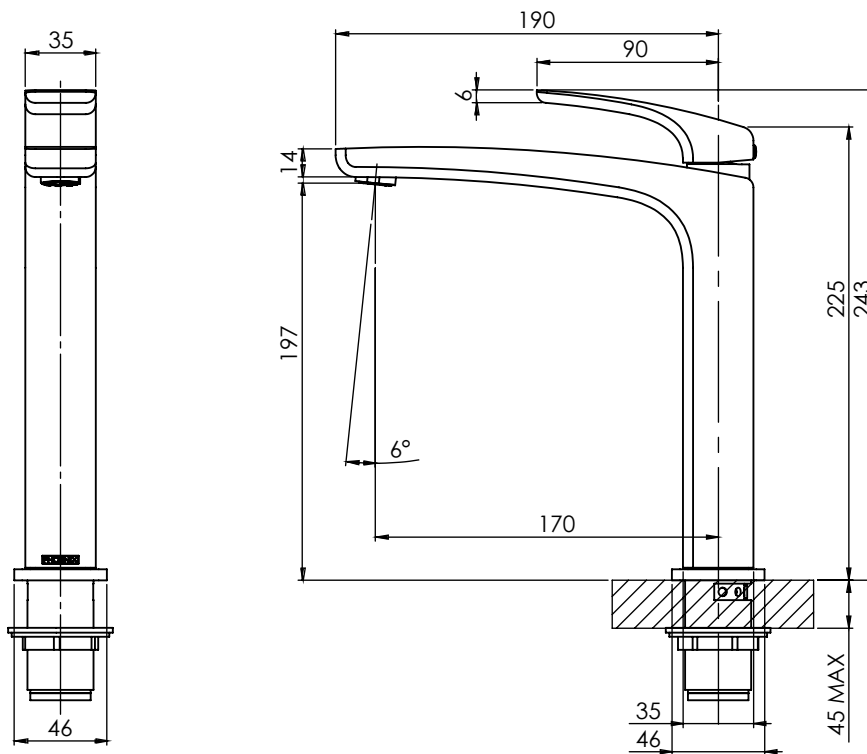

PLEASE [CLICK HERE TO VIEW FULL WARRANTY](#)

While we aim to ensure the specifications shown are correct at time of printing, Phoenix Tapware reserves the right to make modifications without prior notice. Always use the physical product measurements for mark-ups and roughing-in as the line drawing shown may differ from the actual product over time. All measurements are shown in millimetres.

Designed and Registered in Australia by Phoenix Industries Pty. Ltd

V260917

www.phoenixtapware.com.au
03 9780 4200



PHOENIX

SPECIFICATIONS

RUSH

SINK MIXER

PRODUCT CODE: RU730-40
 FINISH: BRUSHED NICKEL
 WELS: 5 STAR - 5.5 LT/MIN



PARTS LIST

1. MIXER BODY
2. GRUB SCREW M4X6MM
3. GRUB SCREW M4X4MM
4. CARTRIDGE SEAT EXTENSION
5. O-RING 20X2.75MM
6. 25MM CARTRIDGE
7. MIXER HANDLE
8. SCREW CAP
9. MIXER LOCKNUT
10. O-RING 22X2.0MM
11. MIXER DOME
12. AERATOR RETAINER
13. AERATOR
14. O-RING 16X1.5MM
15. MIXER SWIVEL TAIL
16. SWIVEL PLATE
17. RUBBER WASHER
18. WASHER
19. TAIL LOCK RING
20. NYLON BEARING
21. SWIVEL STOP SCREW
22. O-RING 22X1.75MM
23. HOSE SWIVEL ADAPTER
24. FLEXIBLE HOSE 450MM HOT
25. FLEXIBLE HOSE 450MM COLD
26. SWIVEL SPACER
27. LOCKNUT GASKET
28. MIXER TAIL LOCKNUT

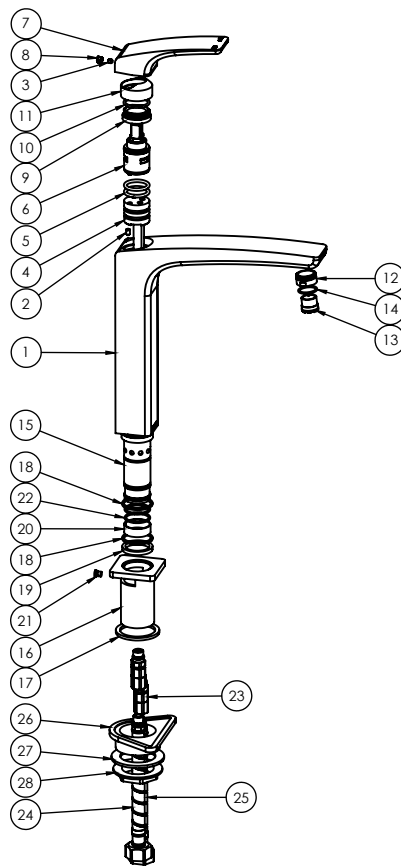

MAINTENANCE AND CARE:

- All surfaces should be cleaned with mild liquid detergent or soap and water.
- Do not use cream cleaners or citrus based cleaning products, as they are abrasive.
- Use of unsuitable cleaning agents may damage the surface. Any damage caused in this way will not be covered by warranty.

PACKAGING INCLUDES

- 1 x Sink Mixer
- 1 x Installation kit
- 1 x 450mm braided flexible cold hose
- 1 x 450mm braided flexible hot hose
- 1 x Installation instructions
- 1 x Warranty card

PLEASE [CLICK HERE](#) TO VIEW FULL WARRANTY

While we aim to ensure the specifications shown are correct at time of printing, Phoenix Tapware reserves the right to make modifications without prior notice. Always use the physical product measurements for mark-ups and roughing-in as the line drawing shown may differ from the actual product over time. All measurements are shown in millimetres.

Designed and Registered in Australia by Phoenix Industries Pty. Ltd
V260917

www.phoenixtapware.com.au
03 9780 4200