



PHOENIX

SPECIFICATIONS

AXIA

BASIN MIXER

PRODUCT CODE: 117-7700-10
 FINISH: MATTE BLACK
 WELS: 6 STAR - 4.5 LT/MIN

INFORMATION:

TEMPERATURE RATING: MIN 1° - MAX 75°
 PRESSURE RATING: MIN 150 kPa - MAX 500 kPa



AVAILABLE IN:



FOR MORE INFORMATION VISIT www.phoenixtapware.com

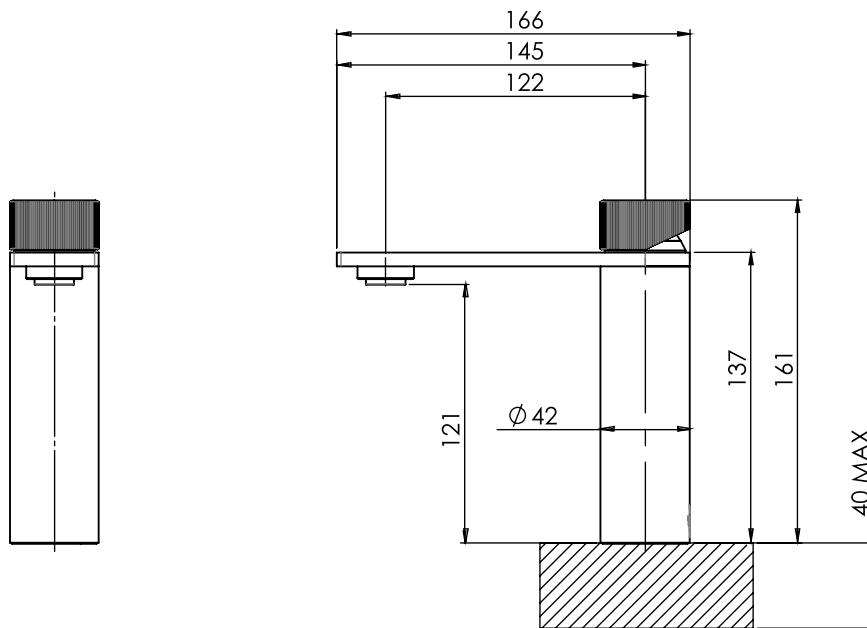

PLEASE [CLICK HERE TO VIEW FULL WARRANTY](#)

While we aim to ensure the specifications shown are correct at time of printing, Phoenix Tapware reserves the right to make modifications without prior notice. Always use the physical product measurements for mark-ups and roughing-in as the line drawing shown may differ from the actual product over time. All measurements are shown in millimetres. Some colours may vary across product types due to differing construction materials. Printed images are a representation only and the colour or finish may vary from the actual product.
 A Registered Design and Trademark of Phoenix Industries Pty. Ltd

www.phoenixtapware.com.au
 03 9780 4200



PHOENIX

SPECIFICATIONS

AXIA

BASIN MIXER

PRODUCT CODE: 117-7700-10
FINISH: MATTE BLACK
WELS: 6 STAR - 4.5 LT/MIN



PARTS LIST

1. SCREW CAP
2. GRUB SCREW M5X6
3. MIXER HANDLE
4. DOME
5. 25MM CARTRIDGE
6. SPOUT ASSEMBLY
7. AERATOR
8. M8 THREADED ROD
9. RUBBER WASHER
10. MIXER FIXING RUBBER GASKET
11. MIXER FIXING PLATE 45MM
12. M8 THREADED NUT
13. HOSE EXTENTION ASSEMBLY
14. HOSE EXTENTION ASSEMBLY
15. RED INDICATOR TAPE
16. BASIN BODY
17. FLEXIBLE HOSE 450MM (HOT)
18. FLEXIBLE HOSE 450MM (COLD)

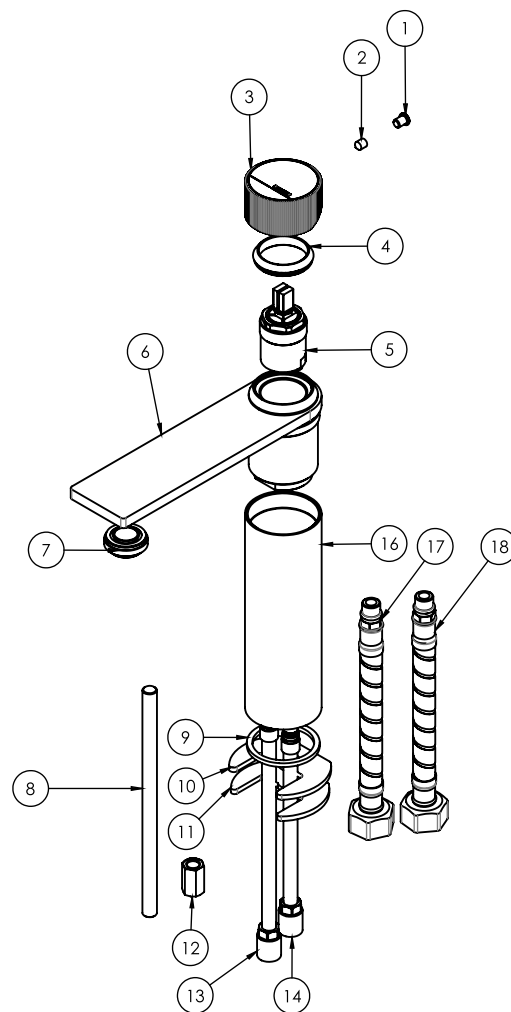

MAINTENANCE AND CARE:

- All surfaces should be cleaned with mild liquid detergent or soap and water.
- Do not use cream cleaners or citrus based cleaning products, as they are abrasive.
- Use of unsuitable cleaning agents may damage the surface. Any damage caused in this way will not be covered by warranty.

PLEASE [CLICK HERE](#) TO VIEW FULL WARRANTY

While we aim to ensure the specifications shown are correct at time of printing, Phoenix Tapware reserves the right to make modifications without prior notice. Always use the physical product measurements for mark-ups and roughing-in as the line drawing shown may differ from the actual product over time. All measurements are shown in millimetres. Some colours may vary across product types due to differing construction materials. Printed images are a representation only and the colour or finish may vary from the actual product.

A Registered Design and Trademark of Phoenix Industries Pty, Ltd

V261119

www.phoenixtapware.com.au
03 9780 4200