



PHOENIX

SPECIFICATIONS

AXIA

TWIN SHOWER / WALL MIXER

PRODUCT CODE:	117-7920-10
FINISH:	MATTE BLACK
WELS:	N/A
INFORMATION:	
TEMPERATURE RATING:	MIN 1° - MAX 55°
PRESSURE RATING:	MIN 150 kPa - MAX 500 kPa



AVAILABLE IN:



FOR MORE INFORMATION VISIT www.phoenixtapware.com

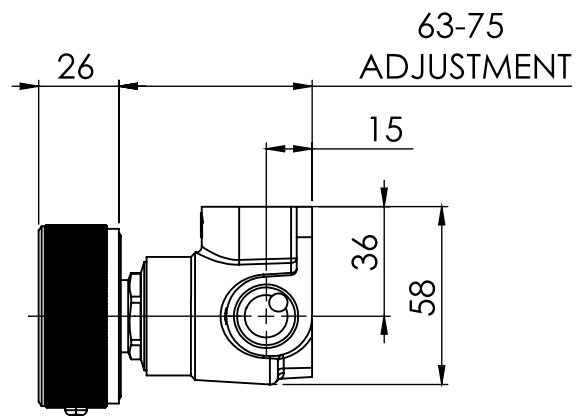
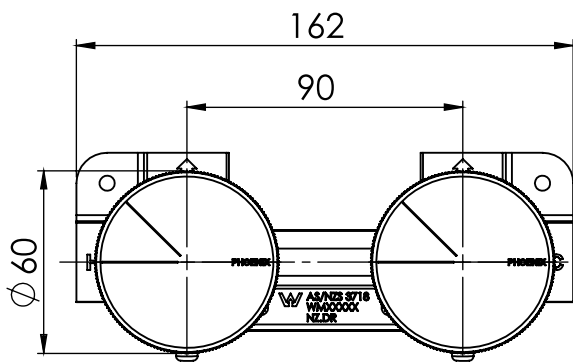

PLEASE [CLICK HERE TO VIEW FULL WARRANTY](#)

While we aim to ensure the specifications shown are correct at time of printing, Phoenix Tapware reserves the right to make modifications without prior notice. Always use the physical product measurements for mark-ups and roughing-in as the line drawing shown may differ from the actual product over time. All measurements are shown in millimetres. Some colours may vary across product types due to differing construction materials. Printed images are a representation only and the colour or finish may vary from the actual product.
A Registered Design and Trademark of Phoenix Industries Pty. Ltd

www.phoenixtapware.com.au
03 9780 4200



PHOENIX

SPECIFICATIONS

AXIA

TWIN SHOWER / WALL MIXER

PRODUCT CODE:

117-7920-10

FINISH:

MATTE BLACK

WELS:

N/A



PARTS LIST

1. MIXER BREACH
2. 33MM PROGRESSIVE CARTRIDGE
3. O-RING
4. CARTRIDGE LOCKNUT
5. MIXER LOCKNUT
6. SPINDLE ADAPTOR
7. SCREW M4X10MM
8. SPINDLE SLEEVE
9. HANDLE ASSEMBLY
10. SCREW
11. WALL INDICATOR COVER
12. O-RING

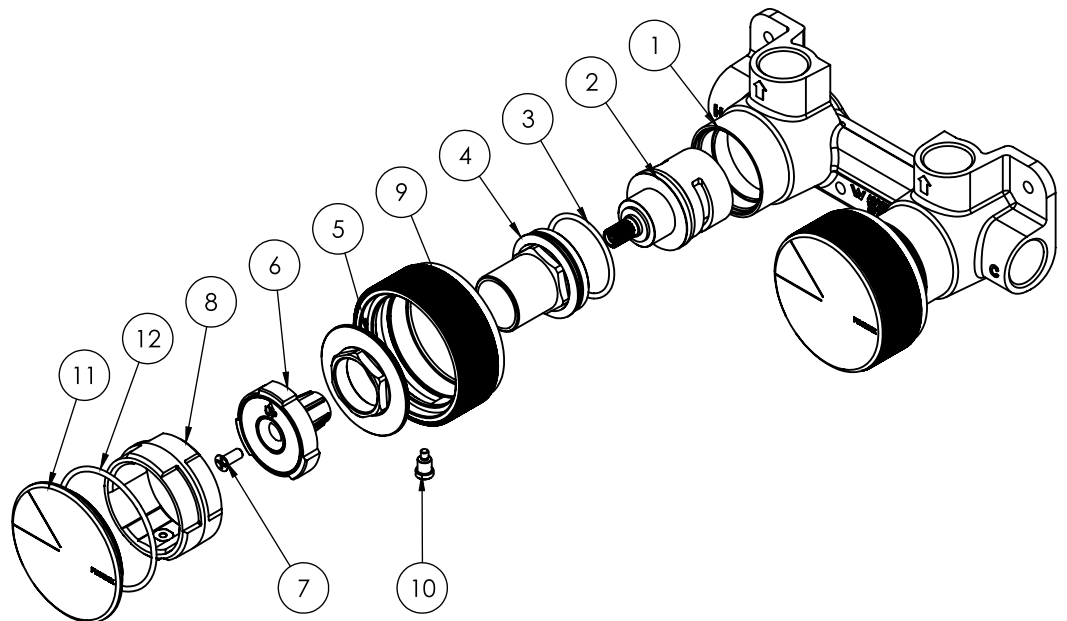

MAINTENANCE AND CARE:

- All surfaces should be cleaned with mild liquid detergent or soap and water.
- Do not use cream cleaners or citrus based cleaning products, as they are abrasive.
- Use of unsuitable cleaning agents may damage the surface. Any damage caused in this way will not be covered by warranty.

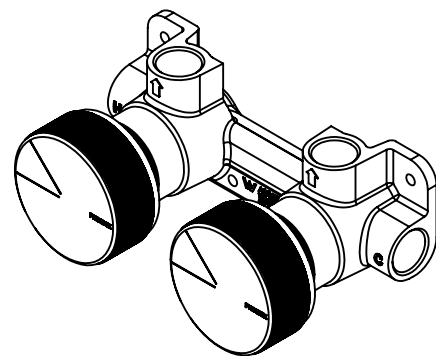

[PLEASE CLICK HERE TO VIEW FULL WARRANTY](#)

While we aim to ensure the specifications shown are correct at time of printing, Phoenix Tapware reserves the right to make modifications without prior notice. Always use the physical product measurements for mark-ups and roughing-in as the line drawing shown may differ from the actual product over time. All measurements are shown in millimetres. Some colours may vary across product types due to differing construction materials. Printed images are a representation only and the colour or finish may vary from the actual product.

A Registered Design and Trademark of Phoenix Industries Pty. Ltd

V261119

www.phoenixtapware.com.au

03 9780 4200