



# PHOENIX

## SPECIFICATIONS

### AXIA

### WALL TOP ASSEMBLIES

PRODUCT CODE: 117-0600-00  
 FINISH: CHROME  
 WELS: N/A

#### INFORMATION:

TEMPERATURE RATING: MIN 1° - MAX 75°  
 PRESSURE RATING: MIN 150 kPa - MAX 500 kPa

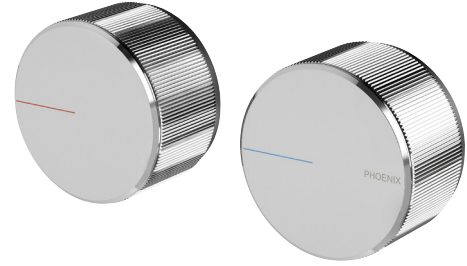

AVAILABLE IN:



FOR MORE INFORMATION VISIT [www.phoenixtapware.com](http://www.phoenixtapware.com)

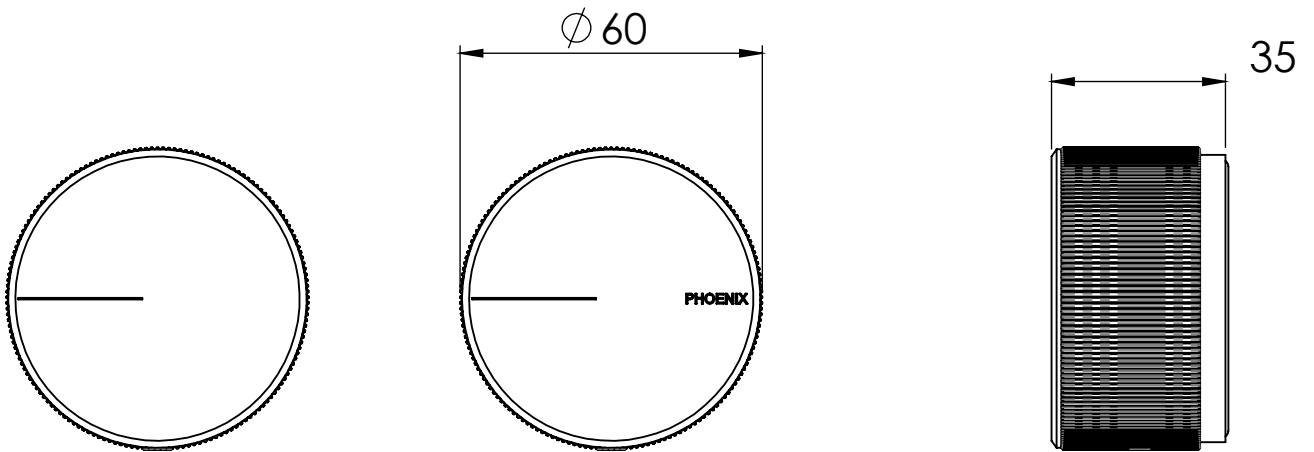

PLEASE [CLICK HERE TO VIEW FULL WARRANTY](#)

While we aim to ensure the specifications shown are correct at time of printing, Phoenix Tapware reserves the right to make modifications without prior notice. Always use the physical product measurements for mark-ups and roughing-in as the line drawing shown may differ from the actual product over time. All measurements are shown in millimetres. Some colours may vary across product types due to differing construction materials. Printed images are a representation only and the colour or finish may vary from the actual product.  
 A Registered Design and Trademark of Phoenix Industries Pty. Ltd

[www.phoenixtapware.com.au](http://www.phoenixtapware.com.au)  
 03 9780 4200



### AXIA

### WALL TOP ASSEMBLIES

PRODUCT CODE:

117-0600-00

FINISH:

CHROME

WELS:

N/A

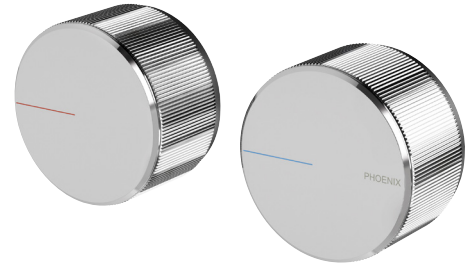

#### PARTS LIST

1. SBA COVER
2. WALL TOP CARTRIDGE
3. WALL TOP BONNET
4. GRUB SCREW M5X5
5. WALL INDICATOR COVER
6. O-RING
7. RUBBER SCREW CAP
8. WALL TOP HANDLE
9. WALL TOP SPINDLE ADAPTOR
10. TAP WASHER
11. WALL TOP FLANGE
12. O-RING
13. FIBRE WASHER

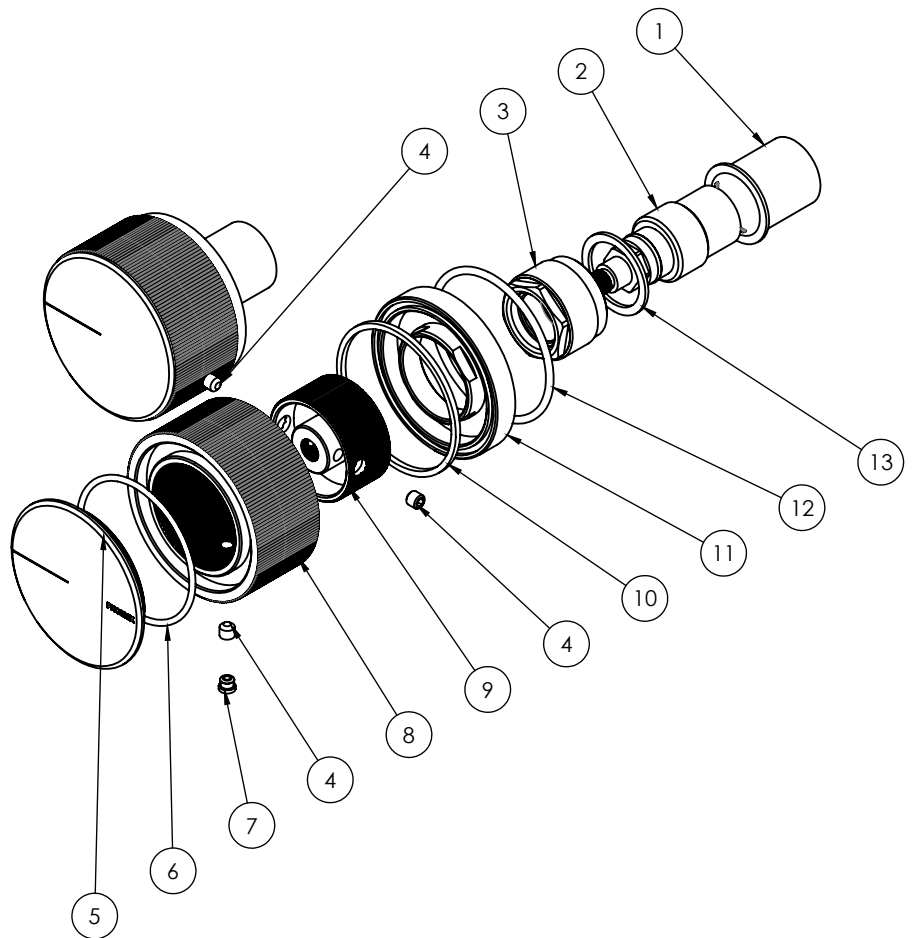

#### MAINTENANCE AND CARE:

- All surfaces should be cleaned with mild liquid detergent or soap and water.
- Do not use cream cleaners or citrus based cleaning products, as they are abrasive.
- Use of unsuitable cleaning agents may damage the surface. Any damage caused in this way will not be covered by warranty.

PLEASE [CLICK HERE TO VIEW FULL WARRANTY](#)

While we aim to ensure the specifications shown are correct at time of printing, Phoenix Tapware reserves the right to make modifications without prior notice. Always use the physical product measurements for mark-ups and roughing-in as the line drawing shown may differ from the actual product over time. All measurements are shown in millimetres. Some colours may vary across product types due to differing construction materials. Printed images are a representation only and the colour or finish may vary from the actual product.

A Registered Design and Trademark of Phoenix Industries Pty. Ltd

V261119

[www.phoenixtapware.com.au](http://www.phoenixtapware.com.au)

03 9780 4200