



## Projix Double Towel Rail 600mm

Product Code:116005

1800 RAYMOR  
[raymor.com.au](http://raymor.com.au)

**Raymor**  
*more like you*

# Projix Double Towel Rail 600mm

## PRODUCT SPECIFICATION

<b>Product Code</b>	116005
<b>Material</b>	Zinc die cast
<b>Finish</b>	Chrome plated
<b>Warranty</b>	Visit <a href="http://www.raymor.com.au">www.raymor.com.au</a>
<b>Rail Length</b>	600mm between centres
<b>Size</b>	600mm
<b>Wall Fixing</b>	Double Point

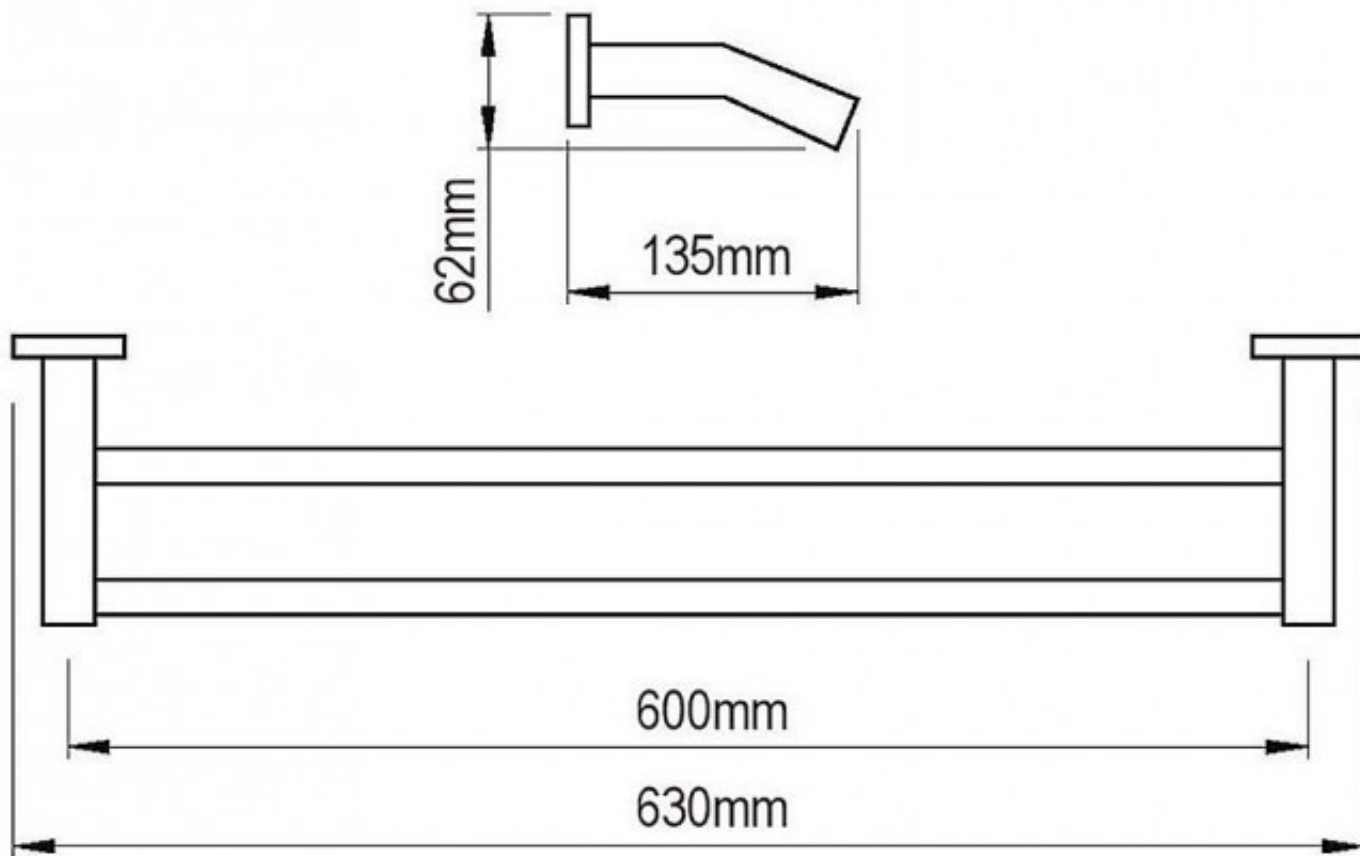

Printed:27/09/2020

© Raymor 2017. All rights reserved.

Version 1 1/09/2017

All measurements are in millimetres and are to be used as a guide only. Specifications and materials may change without notice. Whilst all care has been taken to ensure that all details are correct at the time of print we reserve the right to correct any errors, inaccuracies or omissions or to change or update any details or information at any time without notice.

\*Subject to terms and conditions available at [raymor.com.au](http://raymor.com.au)

**Raymor**  
*more like you*